

Example of equipment layouts for different types of workpiece

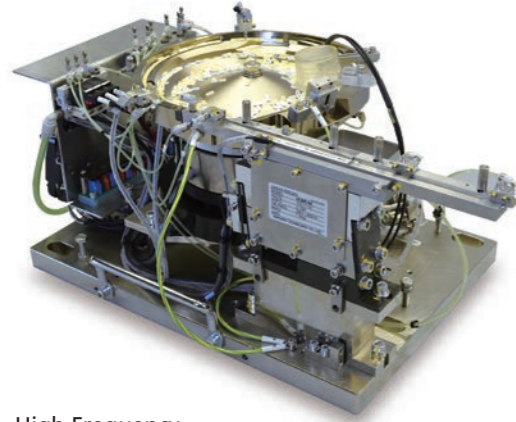

High Frequency  
Mini Parts Feeder unit for chip LED



Mini Parts Feeder unit for  
Ultra Thin Material

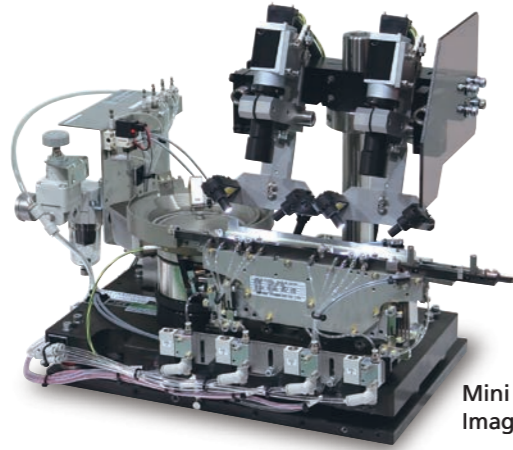

Mini Parts Feeder unit with  
Image Processing System

We have a new slogan in Japan; "ECOing" a combination of "eco" and "ing". This is to promote eco-friendly technological development and manufacturing. Our ecological activities are of course not limited to Japan and practiced in many countries around the world.

SINFONIA TECHNOLOGY CO., LTD. continually upgrades and improves its products.  
Actual features and specifications may therefore differ slightly from those described in this catalog.

Formerly SHINKO ELECTRIC CO., LTD.

**SINFONIA** SINFONIA TECHNOLOGY CO., LTD.

Shiba NBF Tower, 1-30, Shibadaimon 1-chome, Minato-ku, Tokyo, 105-8564, Japan  
TEL +81-3-5473-1864 FAX +81-3-5473-1845

**SINFONIA TECHNOLOGY (SINGAPORE) PTE. LTD.**

96 Robinson Road, #13-02 SIF Building, Singapore 068899  
TEL +65-6223-6122 FAX +65-6225-2729

**PT. SINFONIA TECHNOLOGY INDONESIA**

Graha Paramita 8th Floor Suite E Jl. Denpasar Raya Block D2 KAV. 8 Kuningan, Jakarta 12940 Indonesia  
TEL: +62-21-252-3606 (hunting) FAX: +62-21-252-3608

**SINFONIA TECHNOLOGY (THAILAND) CO., LTD.**

12th Floor Room 1205, 319 Chamchuri Square Building, Phayathai Road, Pathumwan Bangkok Bangkok 10330  
TEL +66-2160-5068 FAX +66-2160-5069

CODE

E97-003

Printed in Japan 1603BIII©

# PARTS FEEDER



**SINFONIA**  
SINFONIA TECHNOLOGY CO., LTD.  
Formerly SHINKO ELECTRIC CO., LTD.

## DUAL MOTION PARTS FEEDERS

DM/DMS Series	2
DMS Series Drive Units	3
DM Series Drive Units	4
Bowls for DM Series	5
Controller for DM Series	6



## PARTS FEEDERS

EA Series	7
ER Series	8
EA/ER Series Dimension	9
EA/ER/DMS Series Bowl Dimension	11
EA/ER/DMS Series Product Combination	13



## LINEAR FEEDERS

LFBR Series Leaf-spring Vibro-isolating type	16
LFB Series Leaf-spring Vibro-isolating type	17
LFG Series Rubber Mount Vibro-isolating type	18
LF Series Direct Mount type	19
MF Series Direct Mount type	20
LF Series Coil-spring Vibro-isolating type	21

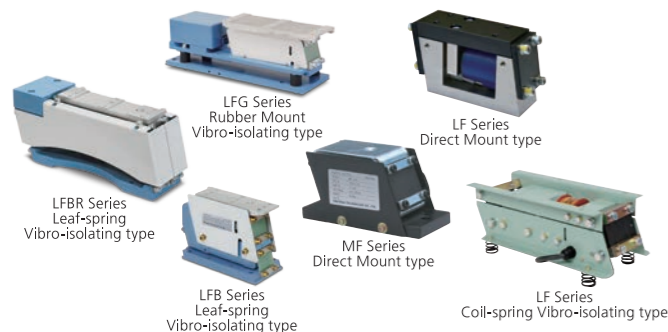

## HOPPERS

Feeder-type Hopper	22
--------------------	----



## CONTROLLERS

C10 Series Variable Frequency Digital Controller	23
Combination Examples	25



## MINI PARTS FEEDERS

ME/HME/HSE Series Mini Parts Feeder	27
LFB/HLFB Series Linear Feeder	29
C9-03VFTC Variable Frequency Digital Controller	30



# DUAL MOTION PARTS FEEDERS

## DM/DMS Series

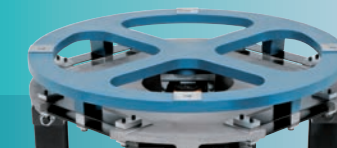

## Realizing Fast, Quiet, and Smooth volumetric feeding

### Features

- Handling components are transported without bouncing while it is operating by adjusting as lowest vertical amplitude as possible.
- Very quiet operation noise because of smooth transportation without bouncing on bowl surface.
- Capable to replace with EA/ER series driving part.

<b>DMS Series</b>	Interchangeable with EA/ER series parts feeders or those of other manufacturers.
<b>DM Series</b>	Accommodates high-speed delivery requirements.

### Applications

- Plastic, easily damaged workpieces for medical and electronic equipment
- For low-noise handling of auto automobile parts or other metal parts
- Precise equipment and other electronic parts that require highly accurate sorting

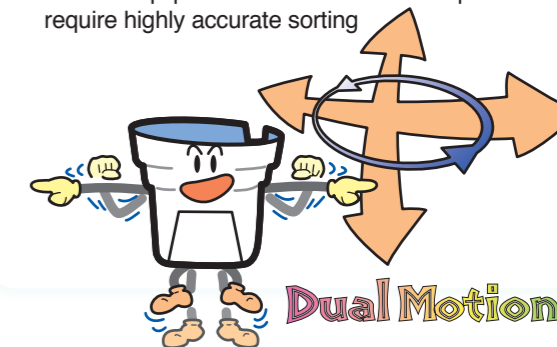

### Dual Motion Principle

#### Friction (transport) controlled through elliptical vibration

Elliptical vibration is achieved by controlling optimal phase difference to the horizontal and vertical amplitudes of bowl vibration. Conveyance using elliptical vibration results from controlling friction, and workpieces thus travel as though gliding along the track.

#### Applied Dual Motion Structure

Dual motion is generated in these parts feeders through feedback of vibration in the horizontal and vertical directions, as shown in the diagram. Sensors detect horizontal and vertical amplitude, thereby allowing separate control.

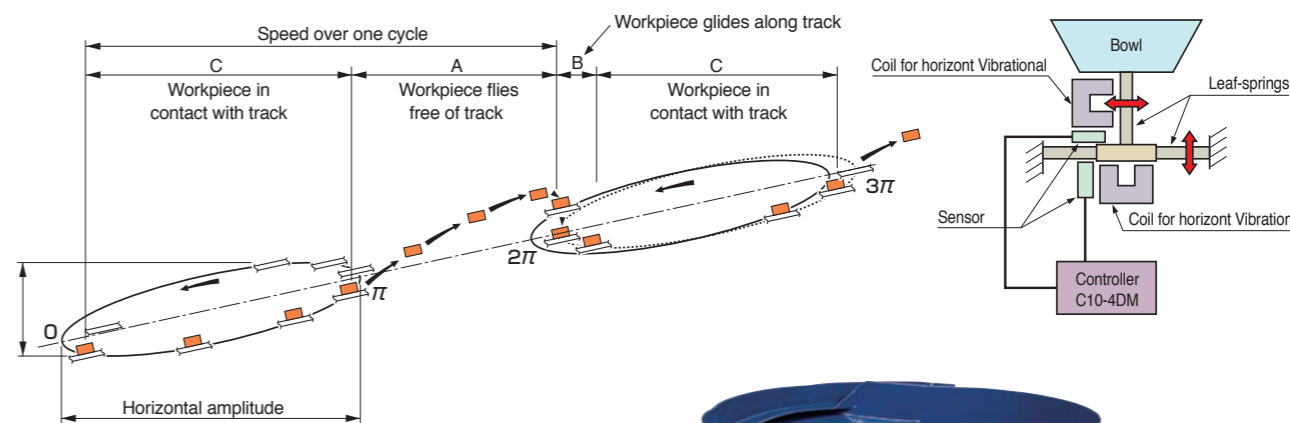



**Dimensions** Accommodates bowls designed for EA and ER and DMS series (see P.11-12) Unit: mm

**DMS-15C/20C**

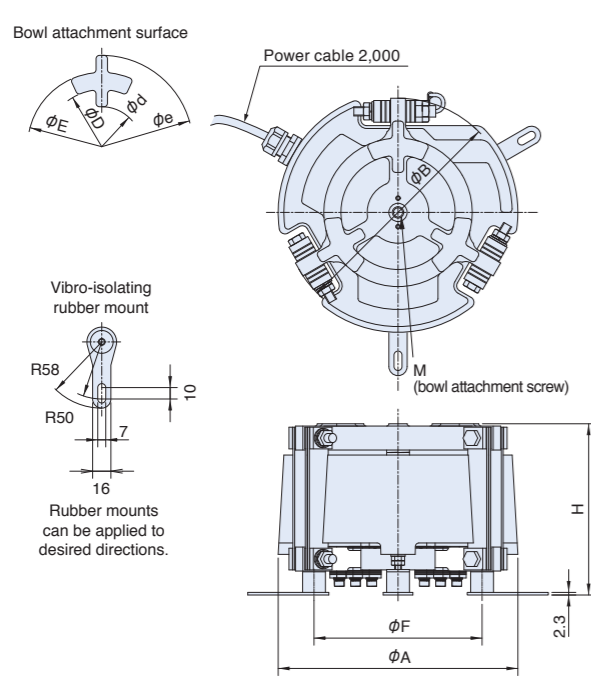

**DMS-25C ~ 45C**

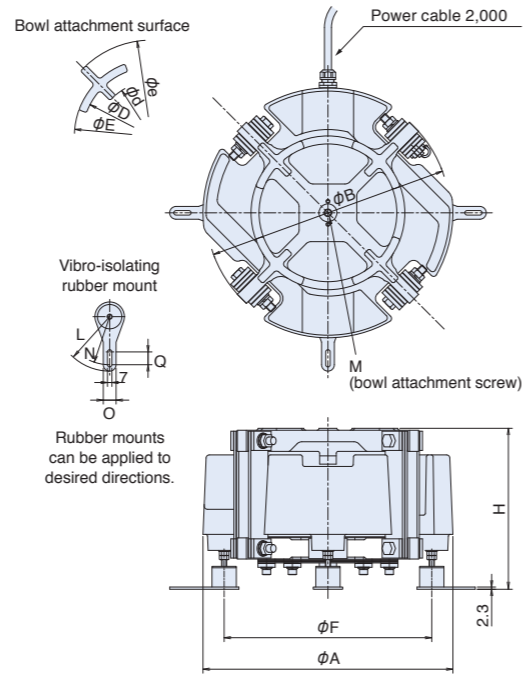

**Drive Unit Specifications**

Model	DMS-15C	DMS-20C	DMS-25C	DMS-30C	DMS-38C	DMS-45C		
Drive unit outer diameter	mm	$\phi 160$	$\phi 210$	$\phi 260$	$\phi 310$	$\phi 390$	$\phi 460$	
Drive unit height	mm	130	150	185	220	250	265	
Drive unit weight	kg	7	14	25	40	70	110	
Rated voltage	V	200						
Rated current	A	Horizontal	0.18	0.3	0.6	2.0	2.0	2.0
		Vertical	0.18	0.3	0.3	0.8	0.8	2.0
Vibration frequency	Hz	100~180			70~110			
Unprocessed bowl diameter (cylindrical)	mm	$\phi 150$	$\phi 200$	$\phi 250$	$\phi 300$	$\phi 375$	$\phi 450$	
Max. bowl diameter (cylindrical)	mm	$\phi 250$	$\phi 320$	$\phi 400$	$\phi 500$	$\phi 600$	$\phi 700$	
Max. amplitude (Unprocessed cylindrical bowl periphery)	mm	Horizontal	0.6			1.0		
		Vertical	0.13			0.3		
Max. loaded weight (workpieces + bowl weight)	kg	2.3	4	8	12.5	17	26	
Cross section area of power cable	mm <sup>2</sup>	0.75 x 5 cores						
Applicable controller		C10-4DM						

**Dimensions Chart**

Unit: mm

Model	H	$\phi A$	$\phi B$	M	$\phi D$	$\phi E$	$\phi F$	$\phi d$	$\phi e$				
DMS-15C	127~130~133	160	150	M8	72	94	130	50	120				
DMS-20C	147~150~153	210	200	M10	100	130	170	70	160				
Model	H	$\phi A$	$\phi B$	M	$\phi F$	L	N	O	Q	$\phi D$	$\phi E$	$\phi d$	$\phi e$
DMS-25C	182~185~188	260	250	M12	216	58	50	16	10	140	160	100	200
DMS-30C	215~220~225	310	300	M12	252	85	75	20	20	172	192	140	240
DMS-38C	245~250~255	390	380	M16	324	85	75	20	20	215	240	170	300
DMS-45C	260~265~270	460	450	M16	390	85	75	20	20	270	300	210	350

**Dimensions** Can be used with DM series bowls only (see P.5) Unit: mm

**DM-30C ~ 45C**

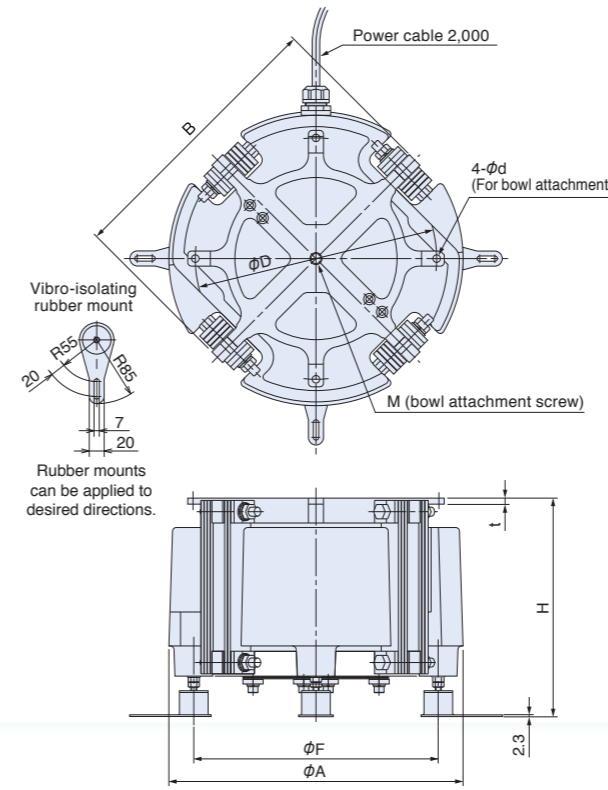

**DM-65C**

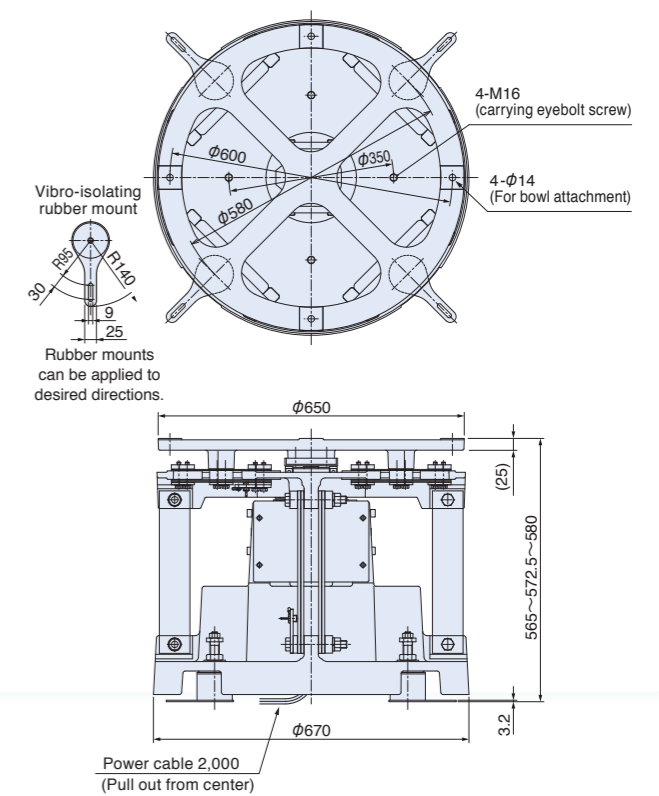

**Drive Unit Specifications**

Model	DM-30C	DM-38C	DM-45C	DM-65C		
Drive unit outer diameter	mm	$\phi 310$	$\phi 390$	$\phi 460$	$\phi 670$	
Drive unit height	mm	290	295	365	572.5	
Drive unit weight	kg	55	80	140	320	
Rated voltage	V	200				
Rated current	A	Horizontal	2.0	2.0	4.0	4.0
		Vertical	0.8	0.8	2.0	2.0
Vibration frequency	Hz	70~110			30~40	
Unprocessed bowl diameter (cylindrical)	mm	$\phi 300$	$\phi 375$	$\phi 450$	$\phi 650$	
Max. bowl diameter (cylindrical)	mm	$\phi 500$	$\phi 600$	$\phi 700$	$\phi 1000$	
Max. amplitude (Unprocessed cylindrical bowl periphery)	mm	Horizontal	1.8			4.0
		Vertical	0.3			1.0
Max. loaded weight	kg	9.2	17.0	27.5	70.0	
Cross section area of power cable	mm <sup>2</sup>	0.75 x 5 cores				
Applicable controller		C10-4DM				

**Dimensions Chart**

Unit: mm

Model	H	$\phi A$	B	M	$\phi D$	$\phi d$	t	$\phi F$
DM-30C	285~290~295	310	290	M12	270	10	8	252
DM-38C	290~295~300	390	370	M16	320	10	8	324
DM-45C	360~365~370	460	440	M16	365	12	10	390

Diagrams show counter-clockwise orientation

Dimensions

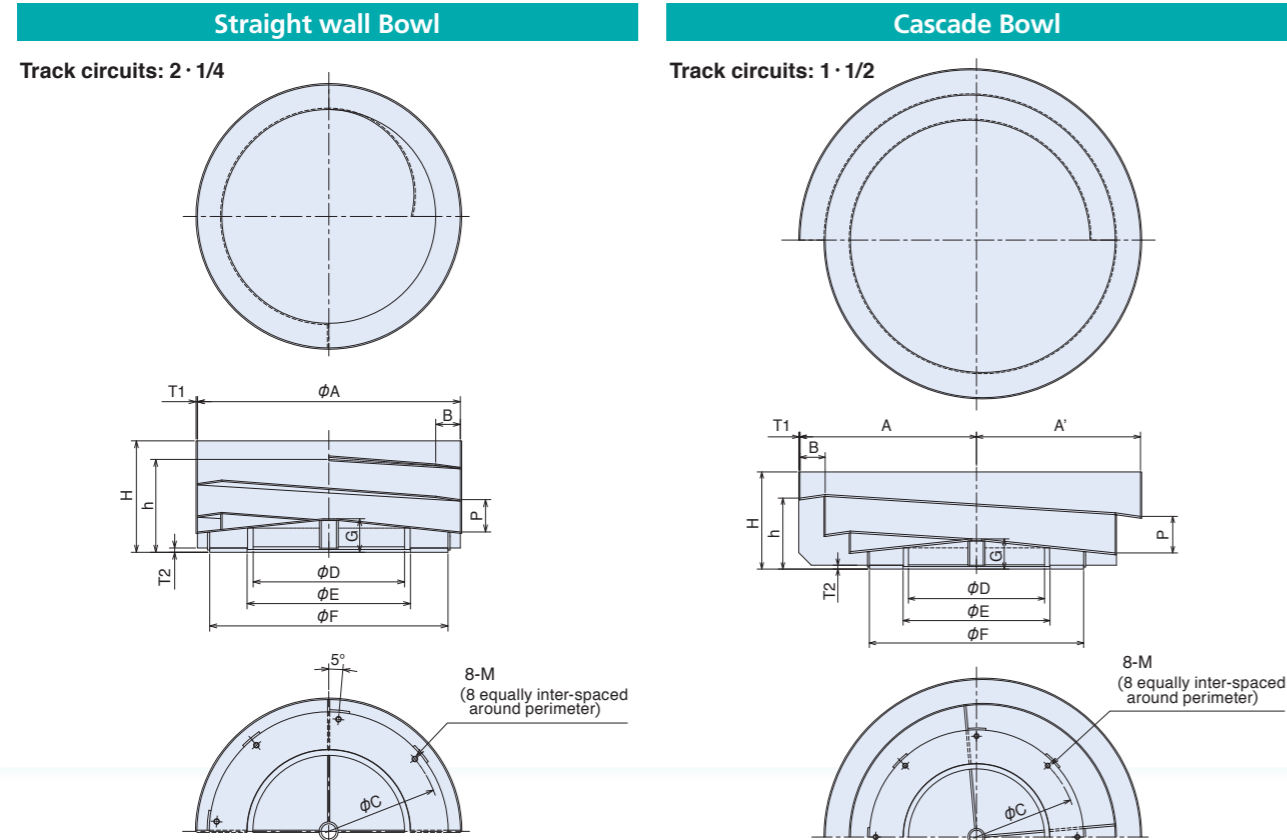

Dimensions Chart

Unit: mm

Straight wall Bowl

Model	φA	B	φC	φD	φE	φF	G	H	h	M	P	T1	T2	Approx. weight (kg)	Capacity (ℓ)
DM-30C	300	25	270	174.7	190.7	290	40	129	105	M8	36	2	6	6.5	0.8
DM-38C	375	35	320	216	232	340	48	159	133	M8	46	2	6	10.0	1.7
DM-45C	450	40	365	282.5	298.5	390	60	197	163	M10	56	3	9	18.0	3.0
DM-65C	650	65	600	363.6	406.4	630	—	302	249.5	M12	90	3	12	54.0	10.0

Cascade Bowl

Model	A	A'	B	φC	φD	φE	φF	G	H	h	M	P	T1	T2	Approx. weight (kg)	Capacity (ℓ)
DM-30C	180	167.5	25	270	143	159	290	32	99	74	M8	38	2	6	5.5	1.6
DM-38C	230	215	30	320	174.7	190.7	340	40	124	92	M8	48	2	6	8.5	3.5
DM-45C	280	260	40	365	216	232	390	51	157	116	M10	58	2	9	13.5	6.0
DM-65C	445	405	80	600	363.6	406.4	630	—	267	197	M12	100	3	12	52.0	18.0

Notes \*1 Standard bowl material is stainless steel.  
\*2 Bowls available with clockwise or counter-clockwise orientation.  
\*3 Charged capacity varies according to the type of workpiece.

\*4 When supplied unprocessed, neither inside nor outside has been surface-treated.  
\*5 When supplying processed, specialized bowls other than standard bowls above can be manufactured.

Straight wall Bowl Selection Guide

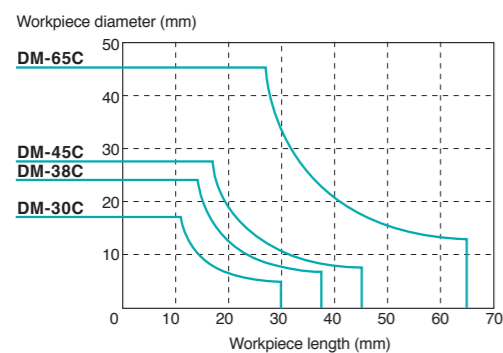

Cascade Bowl Selection Guide

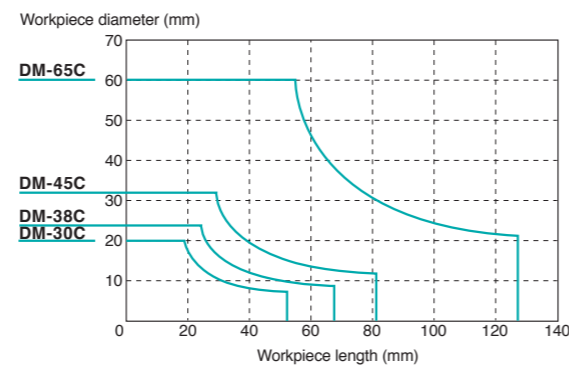

Easy operation !



Dimensions

Unit: mm

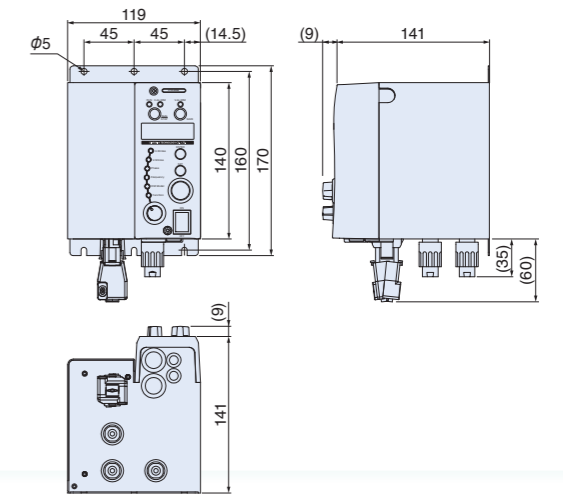

Features

- Simple and easy start up**  
Stroke sensor gain adjustment is not required. Just by selecting a drive unit model at the initial setting stage, necessary parameters are set automatically.
- Easy operation**  
'Selection Dial' and 'Setting Encoder' allow anyone to operate easily.
- Save more space**  
This controller has the same dimensions as C10-5VF/5VFEF and the footprint is reduced by 36% from the previous model.
- Easy wiring**  
Between a driving unit and a controller are connected by connectors.
- Energy-saving auto-tuning**  
Auto tuning function reduces power consumption by tracking the resonance point and keeping vibration frequency on it continuously.
- Electronic control gives optimal vibration**  
Electronic control of horizontal/vertical amplitudes and phase difference provides ideal vibration characteristics for any type of workpiece.

Specifications

Model	C10-4DM	
Input power	AC200-230V ±10%, 50/60Hz	
Control system	PWM system	
Output	Voltage	0~190V
	Vibration frequency	28~45Hz 65~120Hz 90~180Hz
	Max. current	horizontal: 4A vertical: 2A
Operating mode	Standard mode	With automatic resonant frequency tuning function on horizontal amplitude, the controller controls constant amplitude without frequency setting.
	Additional features	Gap of horizontal and vertical amplitude adjusted to constant amplitude.
Additional features	Constant phase control	Choice of 4 pre-set speeds by external signal
	Speed selection	Stops and starts by external signal
	Start/Stop control	Outputs signal synchronized with parts feeder
	Output signal	Start-up time 0.2~4.0 seconds
	Soft start	Delay time 0.2~60 seconds
	On/Off delay timer	3P power plug gives DC12V, max. 80mA
	Sensor power source	Power source synchronized to parts feeder operation (RUN)
Synchronized power source	Function	On/Off control through a triac
	Control system	Same as power source input to controller
	Output voltage	2A
Other	Max. current	Over 1000V
	Noise resistant voltage	0~40°C
	Ambient temperature range	10~90% (No condensation)
	Ambient humidity range	Indoor (Place where no corrosive gas, and dust.)
	Applicable Space	Japan Paint Industry Association U75-70D
	Color of case	2.0kg
Weight	Compatible equipment	DM-30C, 38C, 45C, 65C DMS-15C, 20C, 25C, 30C, 38C, 45C

# PARTS FEEDERS

EA Series 100~180Hz

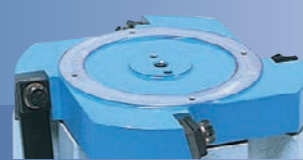

Pictures show counter-clockwise orientation

## For handling a wide range of very small, precision workpieces

With high vibration frequencies of 100 to 180 Hz and small amplitude of 0.6 mm, this series is ideal for very small (10 mm or less), high precision or ultra thin workpieces. Can accommodate bowls ranging from 150 to 700 mm in diameter for highly reliable conveyance.

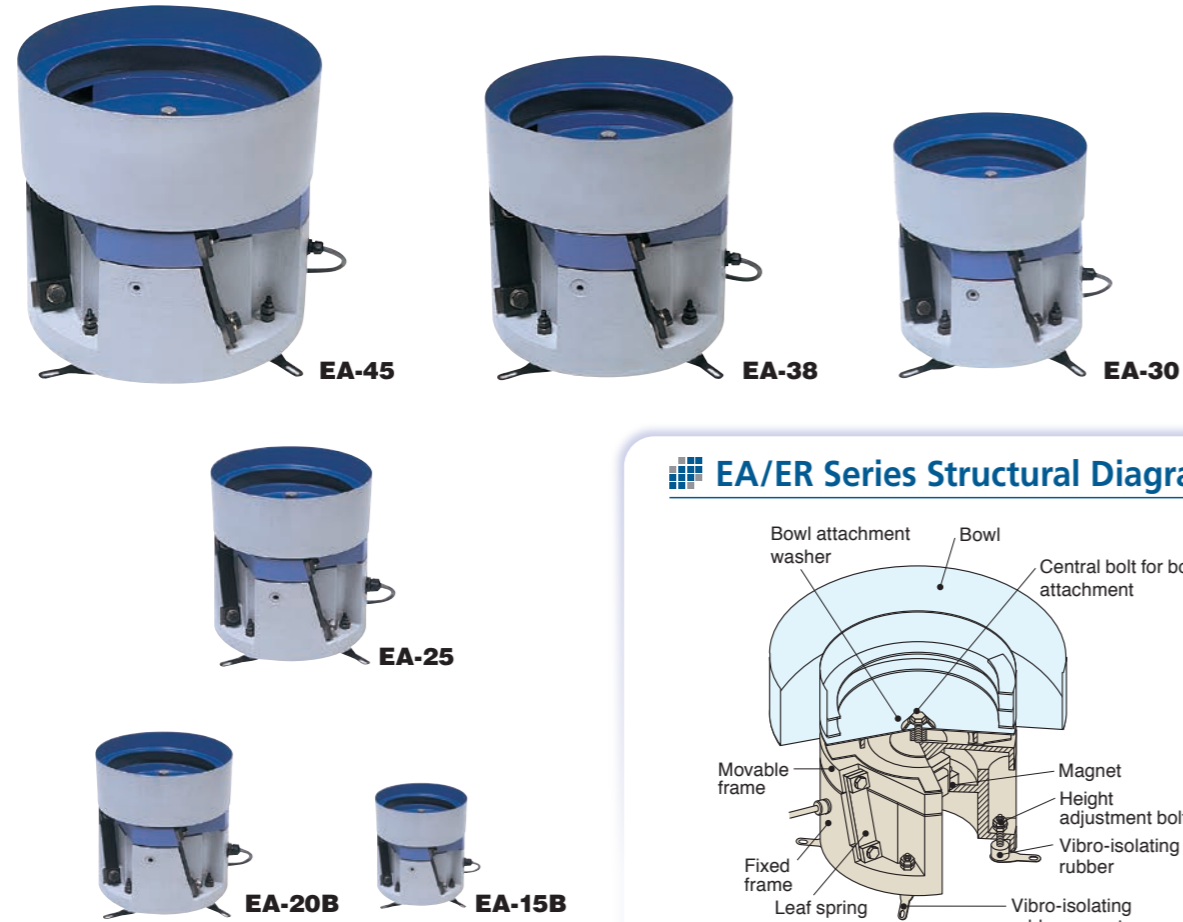

### EA/ER Series Structural Diagram

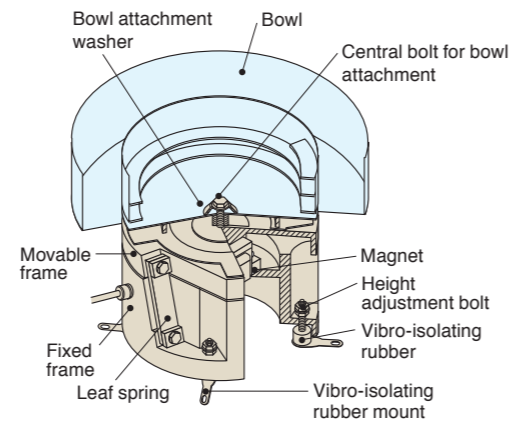

# PARTS FEEDERS

ER Series 50~90Hz

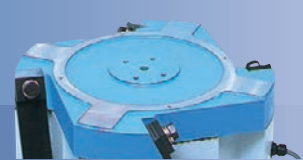

Pictures show counter-clockwise orientation

## Steady feeding of various sizes of workpieces

With low vibration frequencies of 50 to 90Hz and a large amplitude of 1.2 mm, this series is suited to workpieces from 10 mm up in size. Bowl diameters from 250 to 1100 mm can be accommodated, to give powerful feeder performance.



### Specifications

Model	EA-15B	EA-20B	EA-25	EA-30	EA-38	EA-45
Drive unit outer diameter	mm	φ165	φ210	φ260	φ310	φ460
Drive unit height	mm	133	155	190	220	280
Drive unit weight	kg	8	16	30	48	115
Leaf-spring attachment angle	degree	15				
Rated voltage	V	200 (*1)				
Rated current	A	0.35	0.8	1.5	2.0	3.0
Vibration frequency	Hz	100~180				
Unprocessed bowl diameter (cylindrical)	mm	150	200	250	300	450
Max. bowl diameter (cylindrical)	mm	250	330	420	500	700
Max. amplitude (periphery of standard cylindrical bowl)	mm	0.6			0.8	
Max. loaded weight (workpieces + bowl weight)	kg	2.3	4	8	12.5	26
Cross section area of power cable	mm <sup>2</sup>	0.75 x 3 cores			1.25 x 3 cores	
Compatible controllers	AC200V	C10-1VF/1VFEF		C10-3VF/3VFEF		
	AC100V	C10-1VF/1VFEF+C10-TR		C10-3VF/3VFEF+C10-TR		

Note \*1 With an AC100V power source, use optional C10-TR transformer.

### Specifications

Model	ER-25B	ER-30B	ER-38B	ER-45B	ER-55B	ER-65B	ER-75B
Drive unit outer diameter	mm	φ260	φ310	φ390	φ460	φ560	φ760
Drive unit height	mm	198	225	264	286	321	321
Drive unit weight	kg	30	48	81	115	160	260
Leaf-spring attachment angle	degree	20					
Rated voltage	V	200 (*1)					
Rated current	A	1.0	1.5	2.0	2.5	5.0	5.0
Vibration frequency	Hz	50~90					
Unprocessed bowl diameter (cylindrical)	mm	250	300	375	450	550	750
Max. bowl diameter (cylindrical)	mm	420	500	600	700	830	1130
Max. amplitude (periphery of standard cylindrical bowl)	mm	1.2				1.4	
Max. loaded weight (workpieces + bowl weight)	kg	8	12.5	17	26	70	125
Cross section area of power cable	mm <sup>2</sup>	0.75 x 3cores		1.25 x 3cores		2.0 x 3cores	
Compatible controllers	AC200V	C10-1VF/1VFEF	C10-3VF/3VFEF			C10-5VF/5VFEF	
	AC100V	*2	C10-3VF/3VFEF+C10-TR			—	

Notes \*1 With an AC100V power source, use optional C10-TR transformer.  
\*2 C10-1VF/1VFEF+C10-TR

Dimensions

Unit: mm

EA-15B / 20B

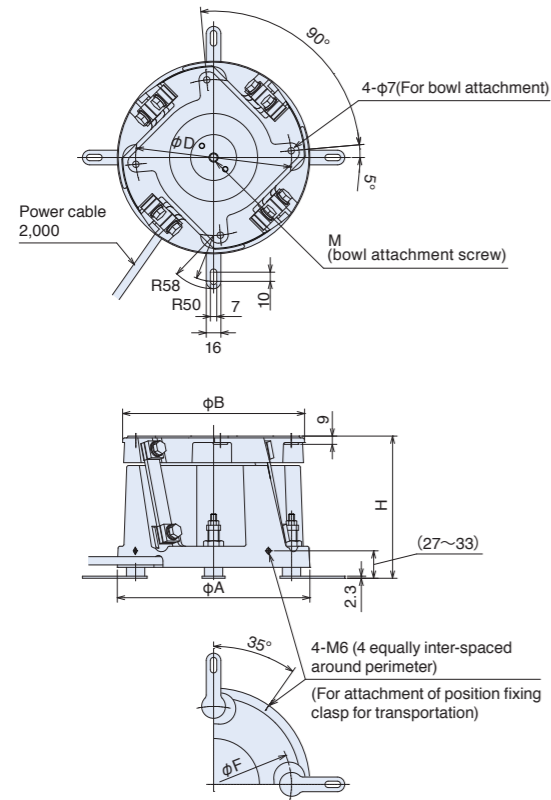

EA-25 / 30 / 38 / 45

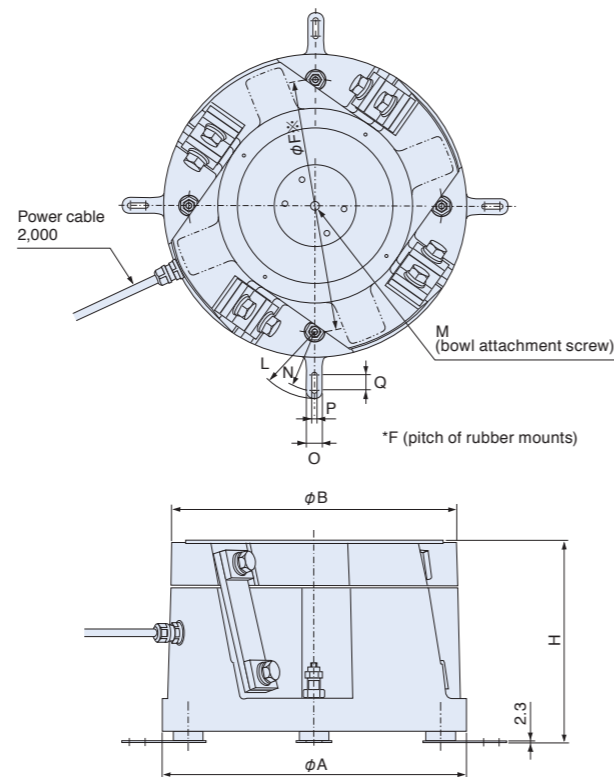

Dimensions

Unit: mm

ER-25B / 30B / 38B / 45B

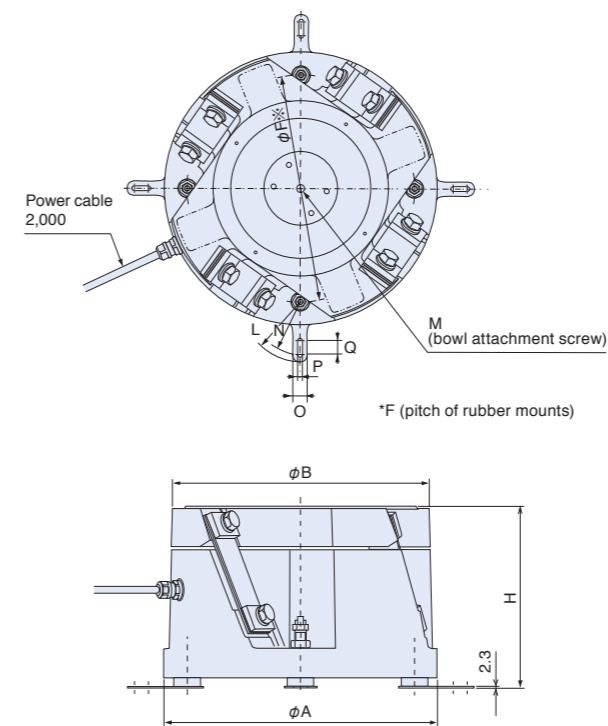

ER-55B / 65B

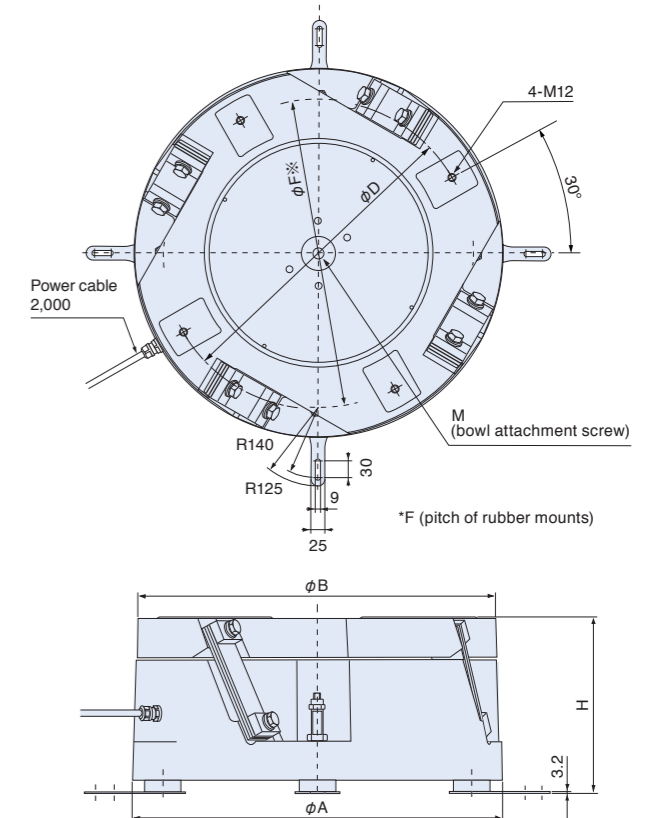

Rubber mounts can be adjusted for any desired direction.

Dimensions Chart

Unit: mm

Model	H	$\phi A$	$\phi B$	M	$\phi F$
EA-15B	130-133-136	165	150	M8	130
EA-20B	152-155-158	210	200	M10	170

Model	H	$\phi A$	$\phi B$	M	$\phi F$	L	N	O	P	Q
EA-25	187-190-193	260	250	M12	216	58	50	16	7	10
EA-30	215-220-225	310	300	M12	252	85	75	20	7	20
EA-38	255-260-265	390	375	M16	324	85	75	20	7	20
EA-45	275-280-285	460	450	M16	390	85	75	20	7	20

ER-75B

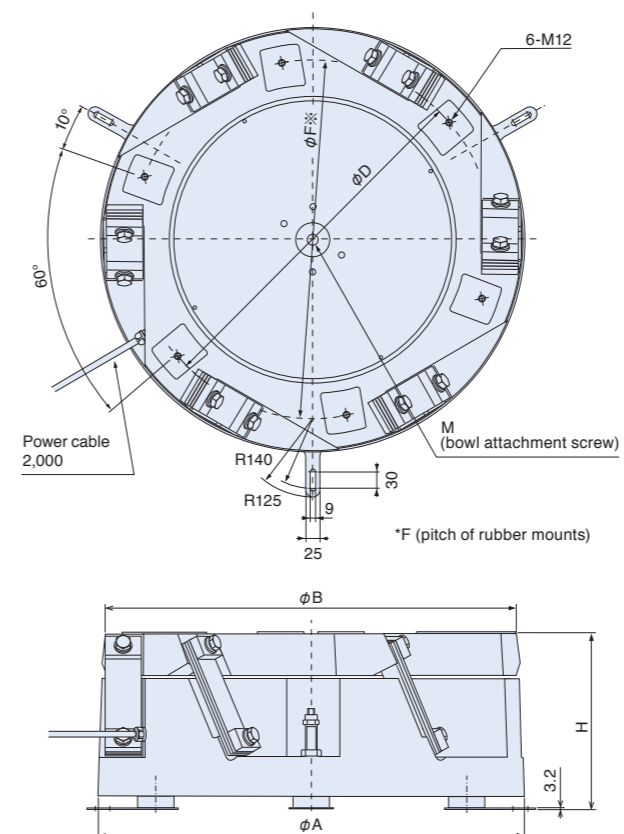

Dimensions Chart

Unit: mm

Model	H	$\phi A$	$\phi B$	M	$\phi F$	L	N	O	P	Q
ER-25B	194-198-202	260	250	M12	216	58	50	16	7	10
ER-30B	218-225-232	310	300	M12	252	85	75	20	7	20
ER-38B	257-264-271	390	375	M16	324	85	75	20	7	20
ER-45B	280-286-292	460	450	M16	390	85	75	20	7	20

Model	H	$\phi A$	$\phi B$	$\phi D$	M	$\phi F$
ER-55B	312-321-330	560	550	460	M20	450
ER-65B	312-321-330	660	650	580	M20	550
ER-75B	312-321-330	760	750	640	M20	640

Diagrams show counter-clockwise orientation

Dimensions

Unit: mm

Straight Wall Bowls

Track circuits: 2 · 1/4

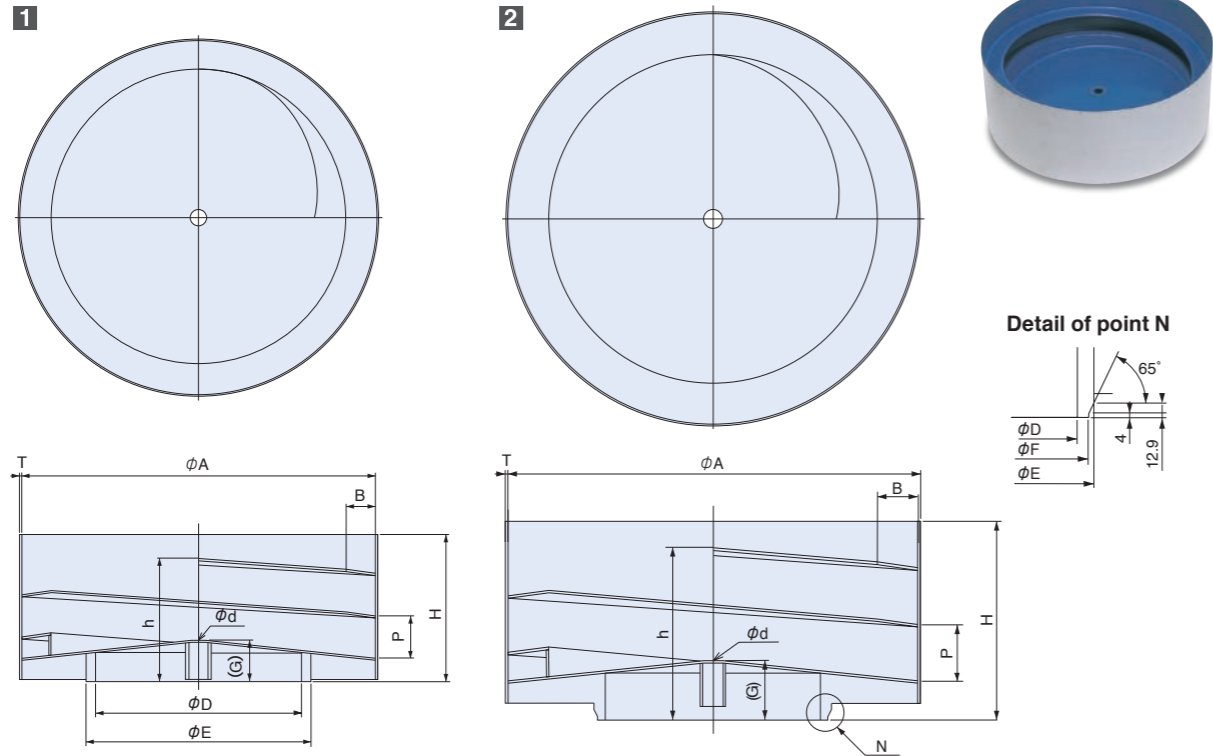

Dimensions Chart

Unit: mm

Model	φA	B	φD	φE	G	H	P	h	φd	T	Approx. Weight (kg)	Capacity (ℓ)
EA/DMS-15	150	12	73.1	89.1	22	70	18	56	8.2	1.5	1.1	0.1
EA/DMS-20	200	18	104	120	25	85	24	69	10.2	1.5	1.8	0.2
EA/ER/DMS-25	250	20	143	159	27	100	30	83	12.2	2	3.2	0.5
EA/ER/DMS-30	300	25	174.7	190.7	35	125	36	101	12.2	2	5.0	0.8
EA/ER/DMS-38	375	35	216	232	43	155	46	129	16.2	2	8.0	1.7
EA/ER/DMS-45	450	40	282.5	298.5	52	190	56	156	16.2	3	15.0	3.0

Model	φA	B	φD	φE	φF	G	H	P	h	φd	T	Approx. Weight (kg)	Capacity (ℓ)
ER-55B	550	55	288.5	318.5	309.2	78	266	76	221	25	3	28	5
ER-65B	650	65	373	406.4	397.2	88	311	90	258	25	3	39	10
ER-75B	750	75	477.8	508	498.7	99	366	108	303	25	3	54	15

Notes 1) Bowls are made of stainless steel, and standard color is differ from color of pictures above. 2) Bowls available with clockwise or counter-clockwise orientation. 3) Capacity varies according to the type of workpiece. \*When supplied unprocessed, neither inside nor outside has been surface-treated.

Straight wall Bowl Selection Guide

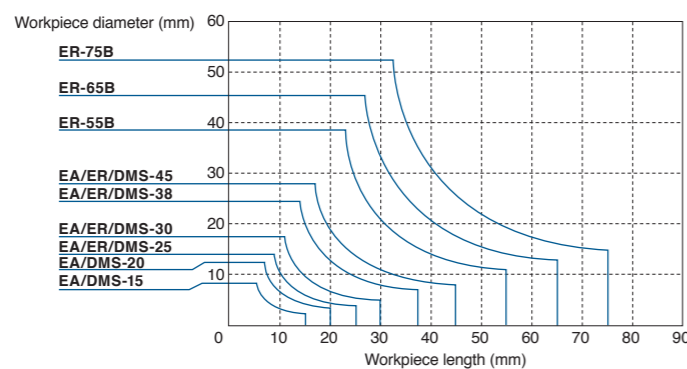

Diagrams show counter-clockwise orientation

Dimensions

Unit: mm

Cascade Bowl

Track circuits: 1 · 1/2

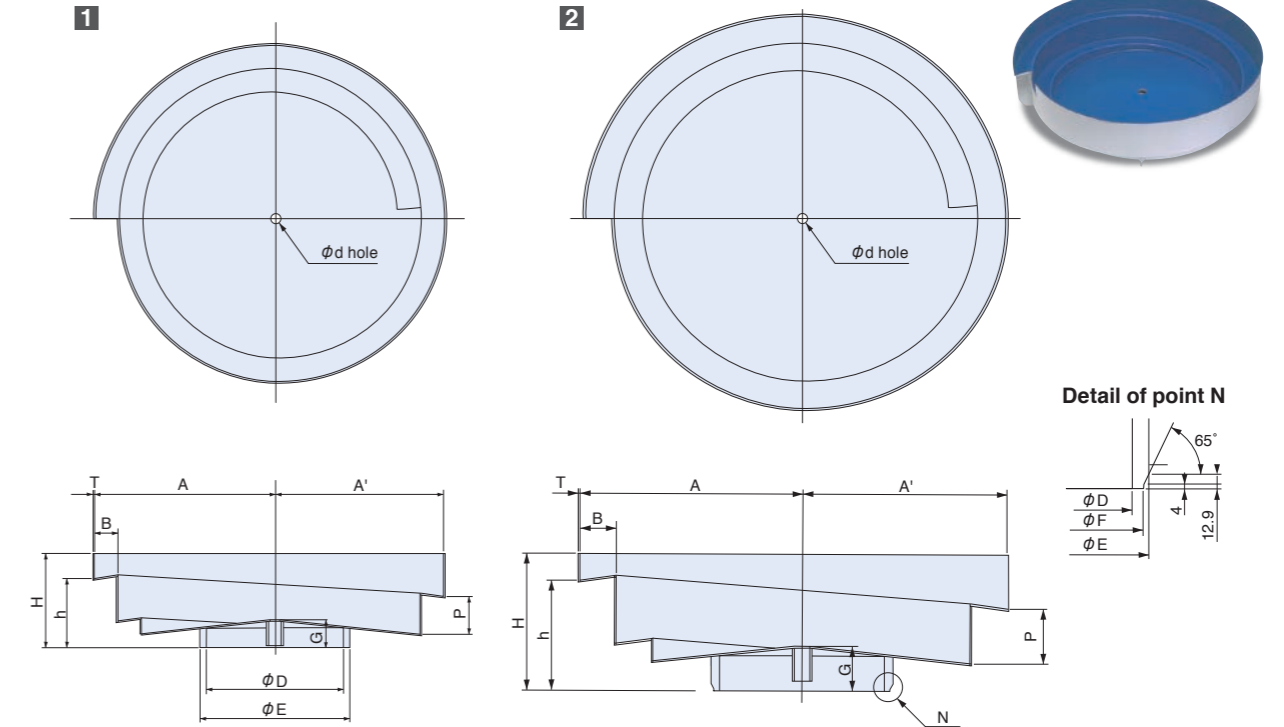

Dimensions Chart

Unit: mm

Model	Approx. diameter	A	A'	B	H	h	P	φd	φD	φE	G	T	Approx. Weight (kg)	Capacity (ℓ)
EA/DMS-15	215	110	102.5	15	65	50	24	8.2	73.1	89.1	23	2	1.3	0.4
EA/DMS-20	280	145	135	20	80	59	30	10.2	104	120	26	2	2.2	0.8
EA/ER/DMS-25	350	180	167.5	25	95	70	38	12.2	143	159	28	2	3.3	1.6
EA/ER/DMS-30	450	230	215	30	120	88	48	12.2	174.7	190.7	36	2	5.4	3.5
EA/ER/DMS-38	540	280	260	40	150	109	58	16.2	216	232	45	2	8	6
EA/ER/DMS-45	650	335	310	50	185	135	72	16.2	282.5	298.5	54	3	16	10

Model	Approx. diameter	A	A'	B	H	h	P	φd	φD	φE	φF	G	T	Approx. Weight (kg)	Capacity (ℓ)
ER-55B	750	390	358	64	240	193	96	25	288.5	318.5	309.2	78	3	26	17
ER-65B	850	445	405	80	306	236	120	25	373	406.4	397.2	88	3	37	20
ER-75B	950	495	455	80	346	256	130	25	477.8	508	498.7	99	3	47	25

Notes 1) Bowls are made of stainless steel, and standard color is differ from color of pictures above. 2) Bowls available with clockwise or counter-clockwise orientation. 3) Capacity varies according to the type of workpiece. \*When supplied unprocessed, neither inside nor outside has been surface-treated.

Cascade Bowl Selection Guide

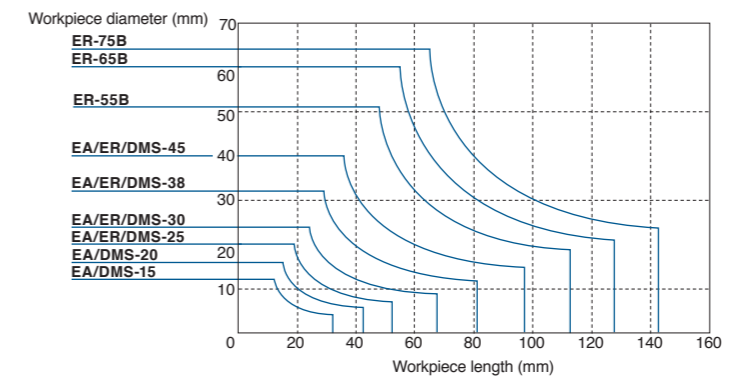

**1 EA/DMS-15+LFB-300**

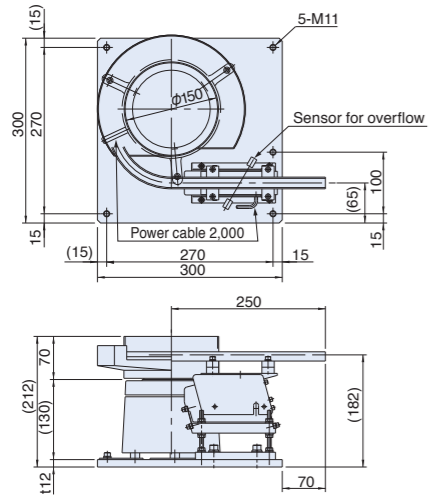

**2 EA/DMS-20+LFB-300**

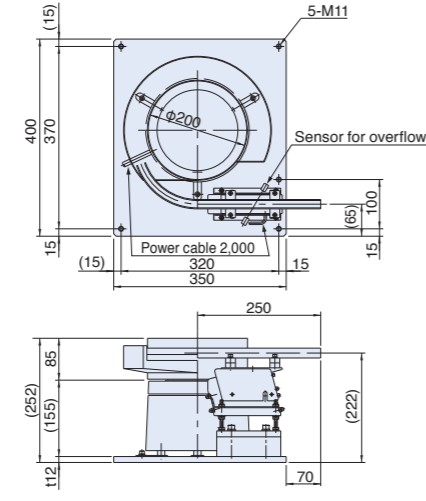

**3 EA/ER/DMS-25+LFB-400**

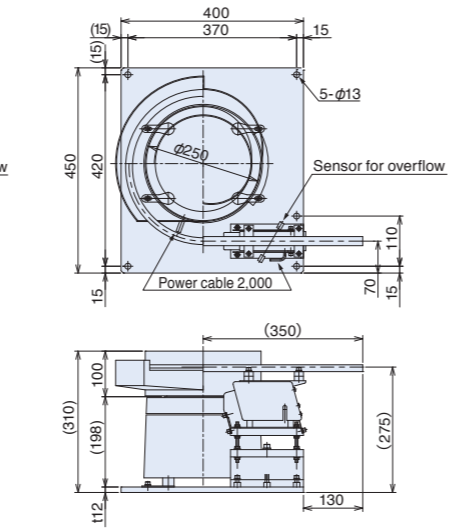

**4 EA/ER/DMS-25+LFG-600**

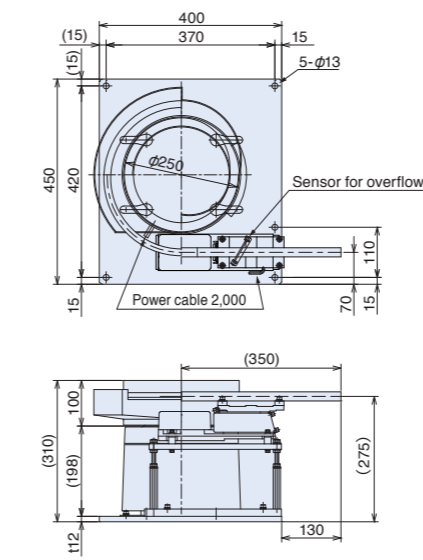

**5 EA/ER/DMS-30+LFB-400**

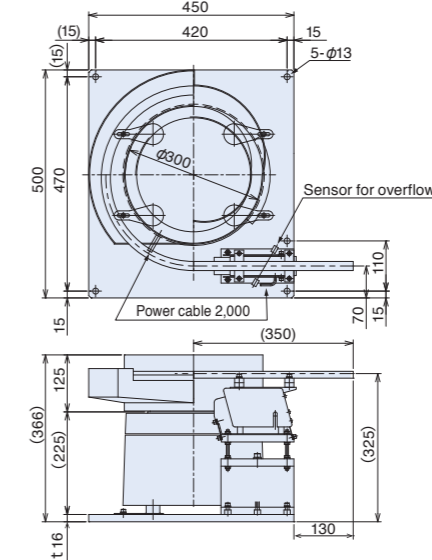

**6 EA/ER/DMS-30+LFG-600**

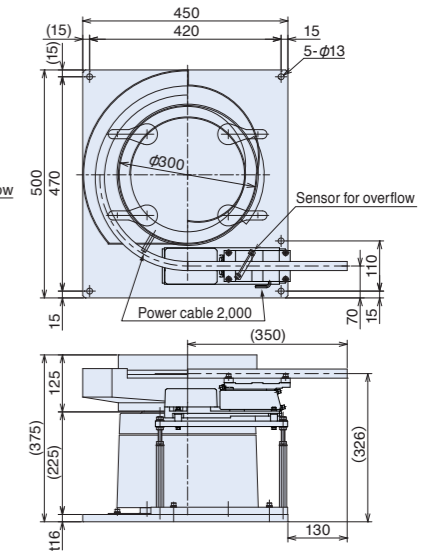

**7 EA/ER/DMS-38+LFB-550**

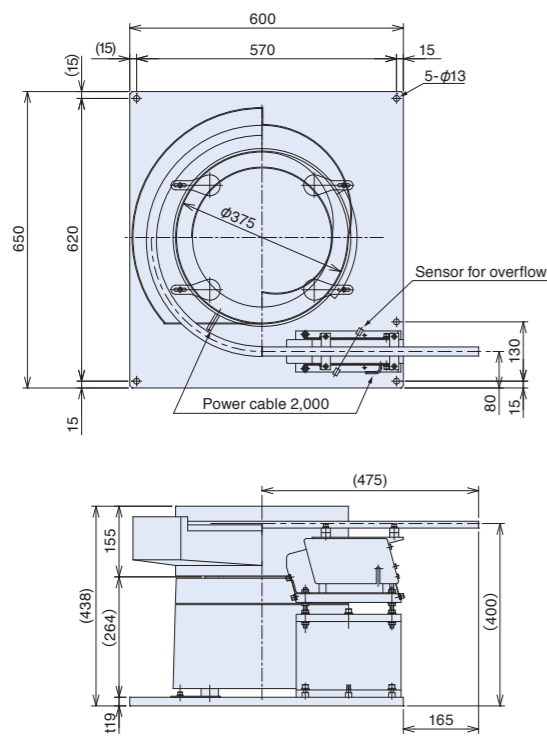

**8 EA/ER/DMS-38+LFG-750**

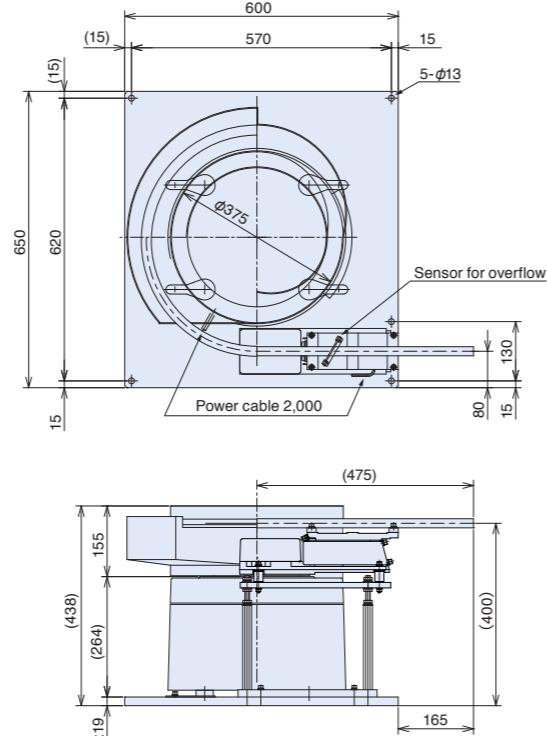

**9 EA/ER/DMS-45+LFB-550**

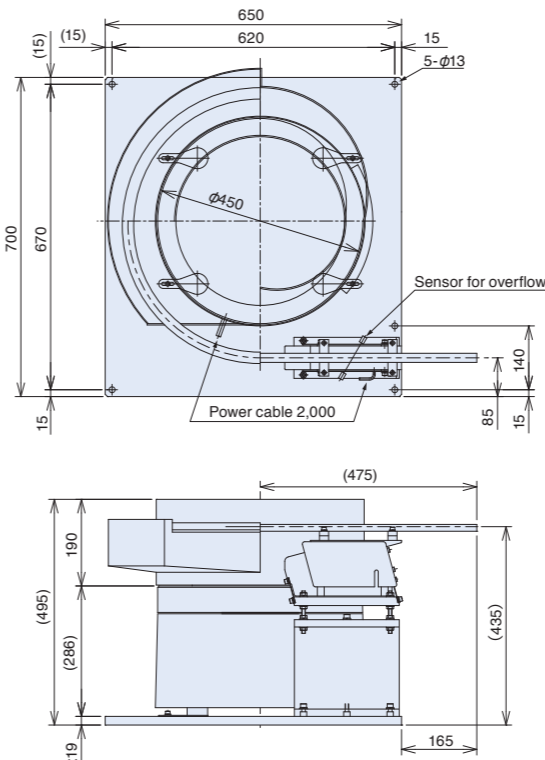

**10 EA/ER/DMS-45+LFG-750**

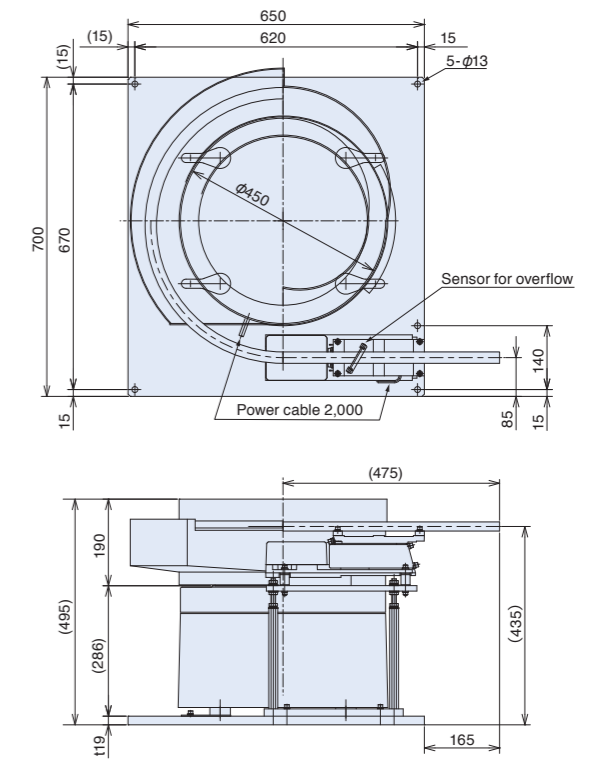



11 ER-55B+LFG-900

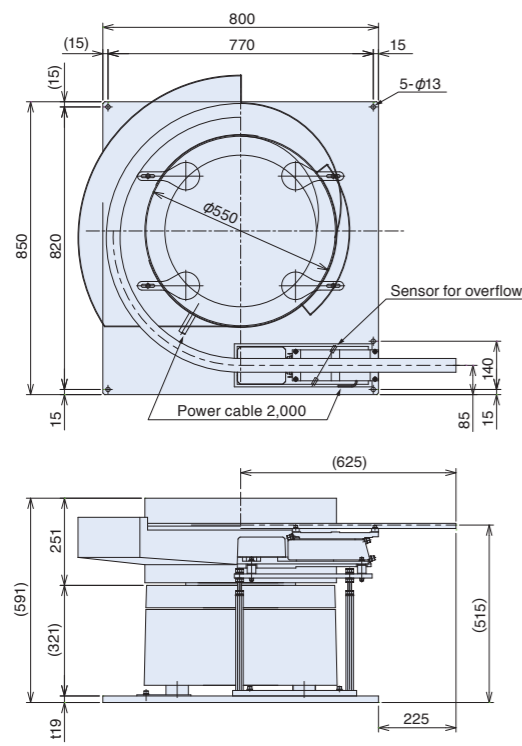

12 ER-65B+LFG-900

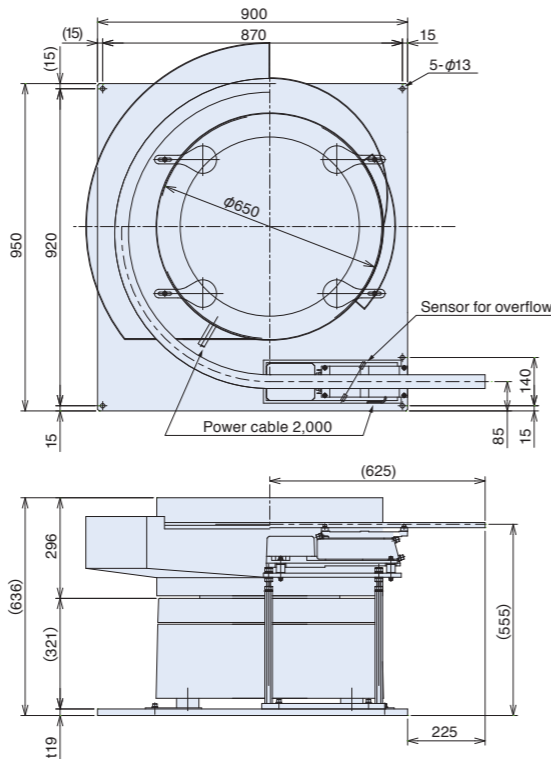

13 ER-75B+LFG-900

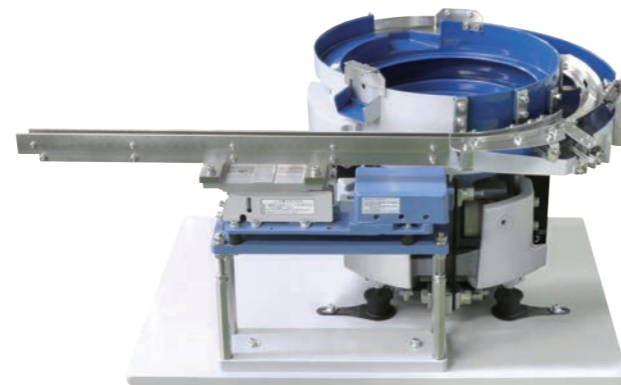
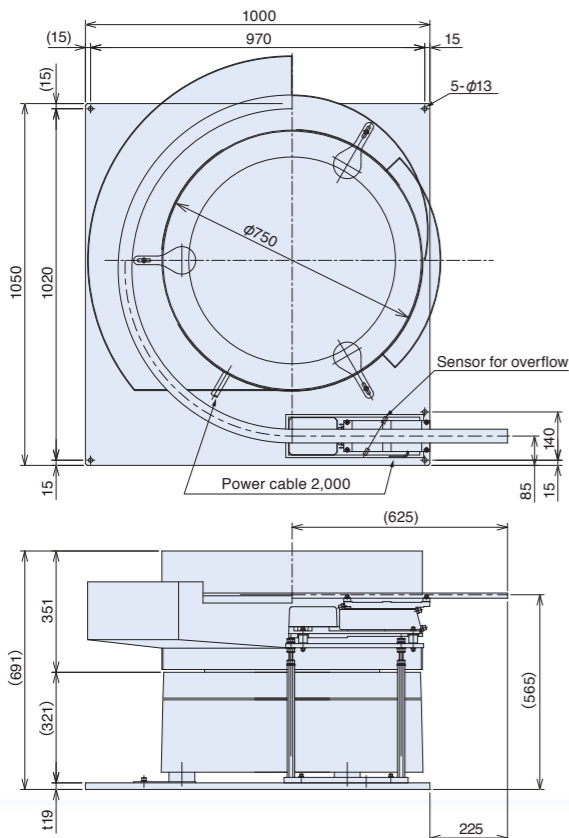

Parts Feeder Model	Linear Feeder Model					
	Leaf-spring vibro-isolating			Rubber-mount vibro-isolating		
	LFB-300	LFB-400	LFB-550	LFG-600	LFG-750	LFG-900
EA/DMS-15	1					
EA/DMS-20	2					
EA/ER/DMS-25		3		4		
EA/ER/DMS-30		5		6		
EA/ER/DMS-38			7		8	
EA/ER/DMS-45			9		10	
ER-55B						11
ER-65B						12
ER-75B						13

Notes:  
All diagrams above show straight wall bowls, however combinations are also possible with track-stepped bowls. (Only bowl diameter and chute exit height vary; all other dimensions are the same for both types of bowl)  
Variety of combinations are possible, depending on the type of workpiece. Please contact us for more details.

Unit: mm

## Low-reaction force linear feeder with less floor reaction

A leaf-spring vibro-isolating type linear feeder with reduced floor reaction. We enabled low-reaction force, high accuracy and smooth parts conveyance through our review of the drive unit mechanism in detail.



### Features

- Low floor reaction**  
By reviewing the drive unit mechanism, floor reaction force has been drastically reduced, compared with the existing leaf-spring vibro-isolating type.
- Leaf spring and Core gap adjustment are unnecessary**  
No troublesome leaf-spring adjustment or even core gap adjustment is necessary, by using the available C9, C10 series variable frequency digital controllers.
- No vibrational interference**  
Because of the middle frequency vibration range (between Full and Half wave), vibrational interference will not occur, when used in combination with other parts feeders.
- Uniform chute vibration angle**  
The entire chute vibration angle become uniformly, and has improved the parts conveyance become much more smoothly.
- Low power consumption**  
Driven near the resonance range enable to gain sufficient stroke in low current.

### Dimensions LFBR-350B/450B/600B Unit: mm

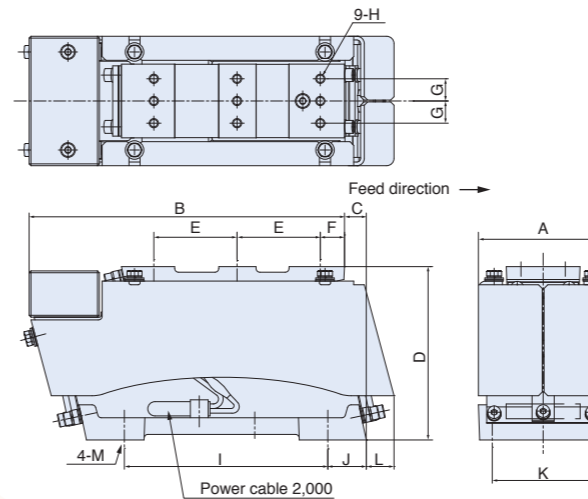

### Specifications

Model	LFBR-350B	LFBR-450B	LFBR-600B	
Rated voltage	V	200		
Rated current	A	0.12	0.14	0.28
Vibration frequency	Hz	95~120	75~100	75~90
Drive unit weight	kg	3.5	5.5	10.5
Leaf-spring angle	degree	12	15	15
Max. amplitude	mm	0.60	0.65	0.75
Cross section area of power cable	mm <sup>2</sup>	0.75 x 3 cores		
Compatible controller	AC200V	C10-1VF / 1VFEF		
	AC100V	C10-1VF / 1VFEF + C10-TR		

### Dimensions Chart

Unit: mm

Model	A	B	C	D	E	F	G	H	I	J	K	L	M
LFBR-350B	70	170.5	12	93.5	45	13	12	M5	110	21	55	14	M8
LFBR-450B	80	205	20	107.5	55	13	14	M6	130	38	60	13	M8
LFBR-600B	95	274.5	25.5	133	75	16.5	19	M6	190	46	75	13	M10

### Chute Specifications, Including Basic Position

Unit: mm

Model	Max. length	Max. width	Min. thickness	Weight range (kg)
	LFBR-350B	350	40	9
LFBR-450B	450	45	12	1.2~2.3
LFBR-600B	600	55	14	2.3~4.0

Model	Basic position (at max. chute length)				
	L1	L2	L3	L4	L5
LFBR-350B	30~110	110~150	67.5	90	39
LFBR-450B	70~150	150~190	82	110	46
LFBR-600B	90~200	200~250	108	150	55

### LFBR Series chute dimensions



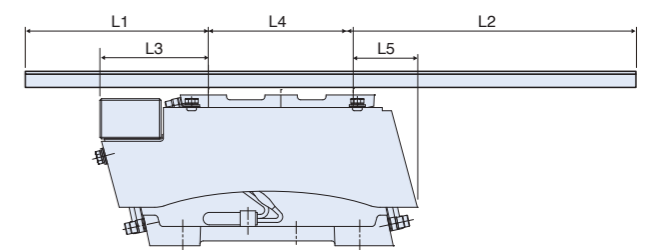

## Generate uniform vibration without adjustment

Use of a variable frequency controller eliminates the need for leaf-spring and core-gap adjustments. Provides uniform vibration with no adjustments necessary, and is easily installed to link up with other equipment, greatly improving ease of use. Can accommodate heavier chute weights and longer overhangs, to widen scope for applications. The drive unit is slim, and with virtually no vibration interference it can easily be combined with parts feeders, to suit wide-ranging combinations. The three models in this series can be used selectively to handle all sizes and shapes of workpiece.

### Features

- **Simple, uniform vibration**  
Use with heavier chutes and longer overhangs opens a wider range of applications. Consistent, uniform vibration is supplied without the need for adjustment.
- **Energy saving type**  
Energy consumption cut by half, compared with our earlier models.



### Dimensions LFB-300/400/550 Unit: mm

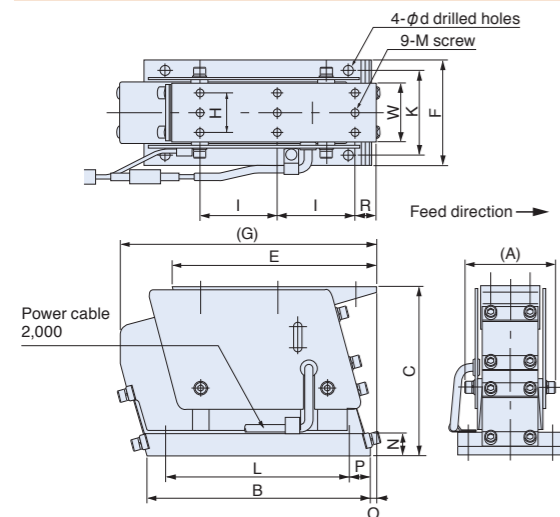

### Specifications

Model	LFB-300	LFB-400	LFB-550
Rated voltage	V 200		
Rated current	A 0.04	A 0.08	A 0.15
Vibration frequency	Hz 90~120	Hz 80~110	Hz 75~100
Drive unit weight	kg 3.0	kg 5.0	kg 10.0
Leaf-spring angle	degree 15		
Max. amplitude	mm 0.6	mm 0.65	mm 0.75
Cross section area of power cable	mm <sup>2</sup> 0.75 × 3 cores		
Compatible controller	AC200V AC100V	C10-1VF / C10-1VFEF C10-1VF+C10-TR / C10-1VFEF+C10-TR	

### Dimensions Chart

Model	A	B	C	E	F	G	H	I	K	L	M	N	O	P	R	W	d
LFB-300	57	135	97	124	65	150	24	45	55	110	5	16	3	10	15	38	6
LFB-400	65	160	120	145	75	180	28	55	60	130	6	16	5	15	15	42	7
LFB-550	79	230	143	200	90	255	38	75	75	190	6	19	5	20	20	52	9

### Chute Specifications, Including Basic Position

Model	Max. length	Max. width	Min. thickness	Weight range (kg)
LFB-300	300	50	6	0.4~1.0
LFB-400	400	50	10	0.8~2.0
LFB-550	550	65	14	1.4~3.5

Model	Basic position (at max. chute length)				
	L1	L2	L3	L4	L5
LFB-300	66	110	40	124	3
LFB-400	105	150	70	145	5
LFB-550	140	210	85	200	5

### LFB Series chute dimensions

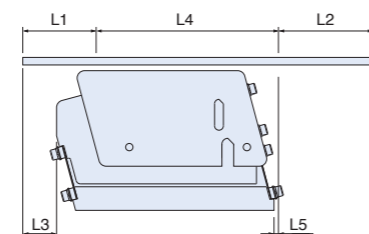

## Accommodate with variety of chutes for ideal conveyance

The variable frequency controller installed as standard eliminates need for leaf-spring and core-gap adjustments. Easy installation and coordination make it much easier to use, and by adjusting position of the rear-end weight, conveyance irregularities can be quickly and easily eliminated. With minimal lateral movement, there is virtually no vibration interference, making it easy to combine with parts feeders for stabilized delivery. The three models in this series allow a full range of equipment combinations, and cover all shapes and sizes of workpiece. A leaf-spring vibro-isolating type linear feeder with reduced floor reaction. We enabled low-reaction force, high accuracy and smooth parts conveyance through our review of the drive unit mechanism in detail.

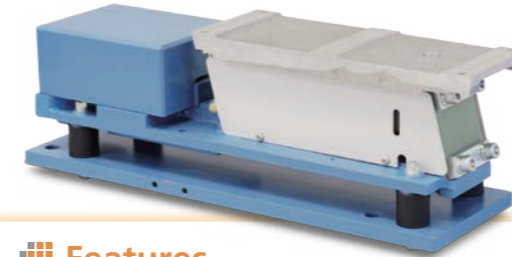

### Features

- **Applicable longer and wider linear chutes.**  
Because new LFG series have longer body from conventional models, more long and wide chutes can be applicable.
- **Stable vibrating conveyance**  
It prevents move of body caused by vibration with using original vibration isolation rubber.
- **Withstand load improved**  
Withstand load improved by applying a long chute
- **Almost same size of drive unit compared with conventional size.** \*Except chute installation tap positions  
Ability improved with same size from conventional size.

### Specifications

Model	LFG-600	LFG-750	LFG-900
Rated voltage	V 200		
Rated current	A 0.2	A 0.37	A 0.41
Vibration frequency	Hz 80~110	Hz 80~110	Hz 80~110
Drive unit weight	kg 7.4	kg 13.2	kg 19.6
Leaf-spring angle	degree 15		
Max. amplitude	mm 0.65	mm 0.75	mm 0.9
Cross section area of power cable	mm <sup>2</sup> 0.75 × 3 cores		
Compatible controller	AC200V AC100V	C10-1VF / C10-1VFEF C10-1VF+C10-TR / C10-1VFEF+C10-TR	

### Chute Specifications, Including Basic Position

Model	Max. length	Max. width	Min. thickness	Weight range (kg)
LFG-600	600	50	10	1.4~3.6
LFG-750	750	65	14	2.2~5.6
LFG-900	900	75	18	4.0~9.8

Model	Basic position (at max. chute length)					
	L0	L1	L2	L3	L4	L5
LFG-600	180	275	29	145	6	6
LFG-750	220	330	74	200	16	16
LFG-900	260	390	92	250	18	18

### LFG Series chute dimensions

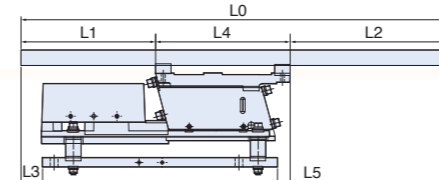

### Dimensions

Unit: mm

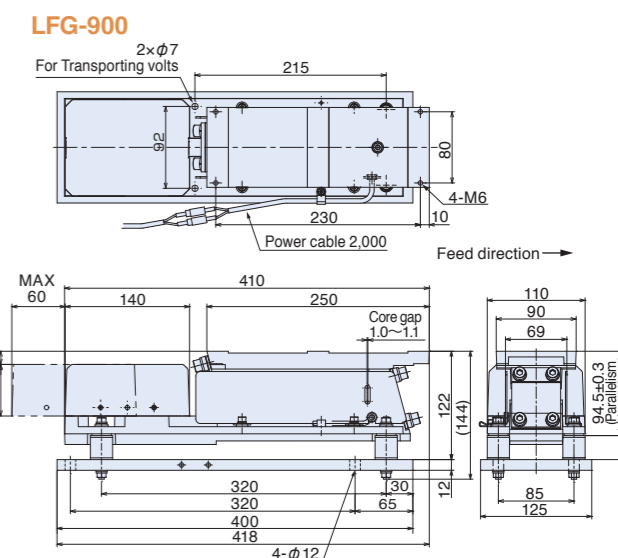
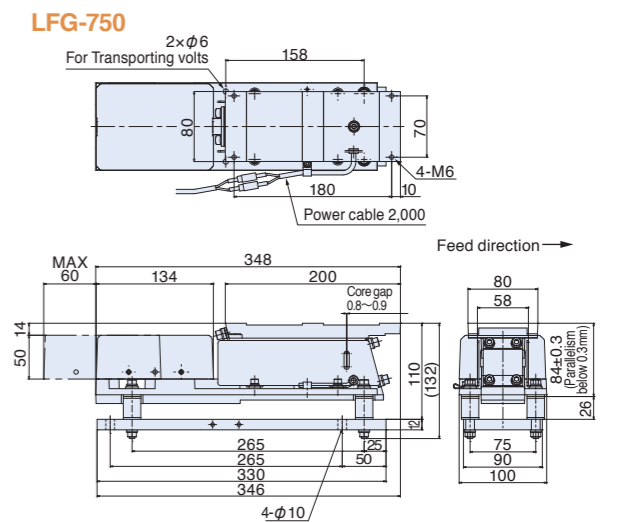
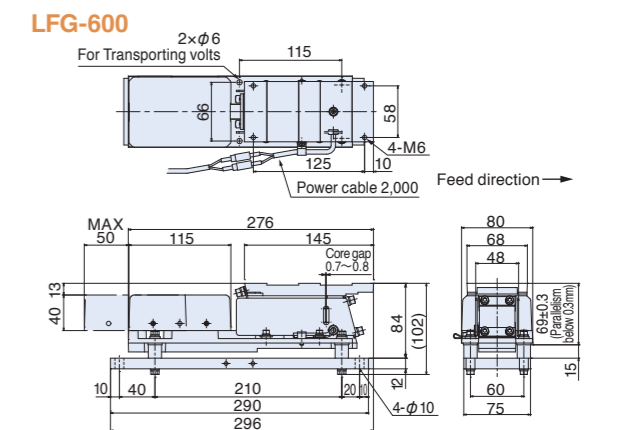



## Simple and compact. Handles a wide range of micro-sized precision parts

Developed for stabilized delivery of non-specialized micro-sized and precision parts, this series uses a small, electromagnetic drive unit that is simple and compact. Unmounted, with full wave operation to give excellent conveyance capacity for small volumes of non-specialized micro-sized workpieces. Maintenance is very straightforward and minimizes costs.

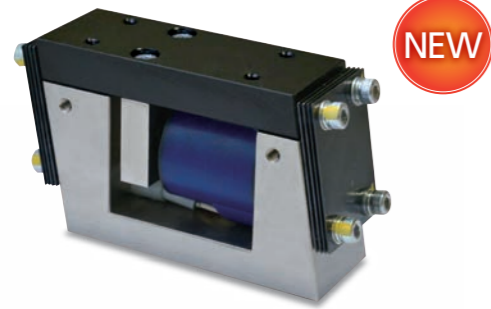

### Features

- **Handles a wide range of small parts**  
Handles a wide range of non-specialized micro-sized, precision parts
- **Simple and low cost**  
Provides a simple, low-cost solution for small-volume applications.
- **Easy, convenient installation**  
Compact design allows easy, convenient installation.

### Dimensions LF-02B/04B

Unit: mm

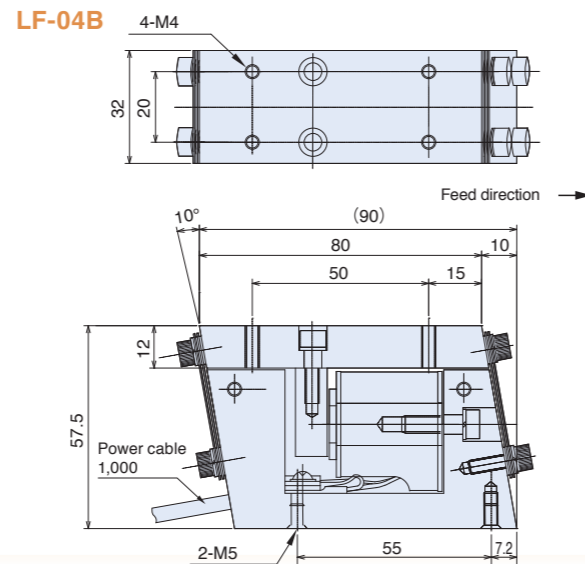
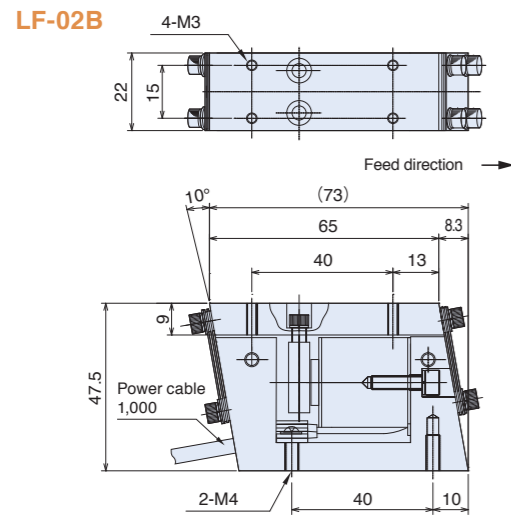

### Specifications

Model	Rated Voltage (V)	Rated Current (A)	Vibration frequency (Hz)	Weight (kg)	Standard compatible controllers
LF-02B	100/110	0.12	100~180	0.45	C10-1VF/1VFEF
LF-04B	100/110	0.16	100~180	1.0	

### Chute Specifications

Unit: mm

Compatible linear feeder	Max. length	Max. width	Max. weight (kg)
LF-02B	180	20	0.2
LF-04B	240	30	0.4



## Compact yet powerful, for speedy delivery and versatile, longer distance conveyance

A new type of electromagnetic drive unit ideal for use with chutes handling very small, flat, and precision parts. Takes full advantage of merits of half wave operation for smooth conveyance of fragile and easily damaged workpieces.



### Dimensions MF-04C/15C

Unit: mm

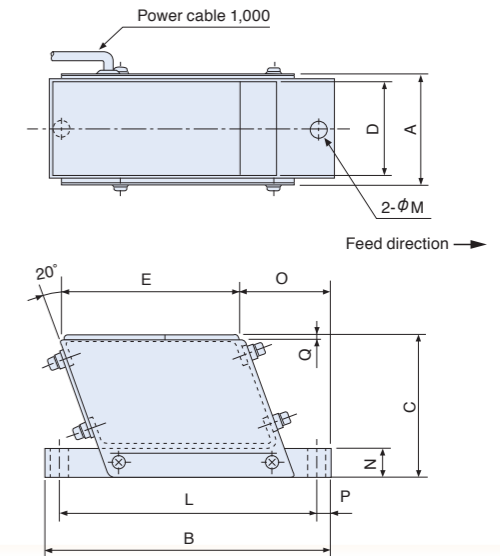

\*Users are asked to drill holes as required for chute attachment.

### Features

- **Compact yet powerful**  
Small unit size with half wave operation capable of longer distance conveyance.
- **Speedy delivery, and versatile, longer distance conveyance**  
High vibration frequency and amplitude give speedy delivery, and can meet a range of longer distance conveyance requirements
- **Easy, convenient installation**  
Compact design takes up little space and allows easy, convenient installation.

### Specifications

Model	Voltage (V)	Current (A)	Vibration (Hz)	Weight (kg)	Standard compatible controllers
MF-04C	100/110 200/220	0.13 0.065	50~90	0.6	C10-1VF/1VFEF
MF-15C	100/110 200/220	0.2 0.1	50~90	1.8	

### Dimensions Chart

Unit: mm

Model	A	B	C	D	E	L	M	N	O	P	Q
MF-04C	46	106	56	38	62	88	7	9	38	9	3.2
MF-15C	56	160	78	52	100	144	9	16	52	8	3.2

### Chute Specifications

Unit: mm

Compatible linear feeder	Max. length	Max. width	Max. weight (kg)
MF-04C	300	35	0.4
MF-15C	450	45	1.5

Note: Chute must straddle drive unit to distribute weight.

## For stable feeding of large volumes of large workpieces

Large-capacity electromagnetic drive unit has strong coil springs positioned at front and rear, and drive controlled by amplitude angle adjustment, to give speedy, steady, straight-line delivery of large-sized workpieces. The low-floored half-wave drive provides uniform amplitude and vibration frequency to eliminate irregularities during high-volume conveyance of large workpieces.



### Features

#### • Large size feeder provides smooth workpiece delivery

Large, vibro-isolating feeder that keeps the flow of workpieces smooth through adjustment of leaf-spring angle.

#### • Fast, stable delivery of high volumes of large workpieces

Extremely high conveyance efficiency allows high-volume delivery of large workpieces.

#### • Dial control for free adjustment of conveyance speed

By changing the vibration frequency and amplitude with the dial control, delivery speed can be freely adjusted.

### Dimensions LF-30/40

Unit: mm

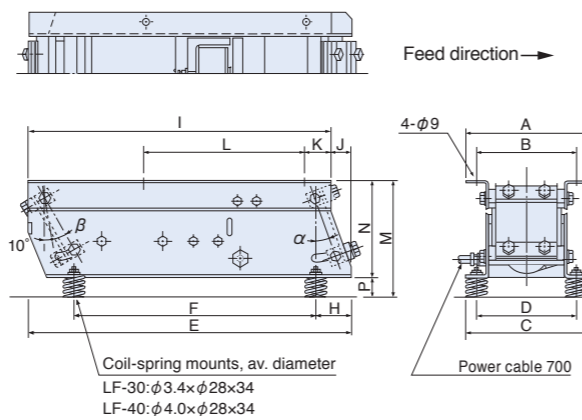

### Specifications

Model	Leaf-spring adjustment angle		Rated voltage (V)	Rated current (A)	Vibration frequency (Hz)	Weight (kg)	Cross section area of power cable (mm <sup>2</sup> )	Standard compatible controller
	$\alpha$	$\beta$						
LF-30	0°~20°	10°~30°	200/220	1.5	50~90	25	1.25 x 3 core	C10-3VF/3VFEF
LF-40	0°~20°	10°~30°	200/220	1.6	50~90	33		

### Dimensions Chart

Unit: mm

Model	A	B	C	D	E	F	H	I	J	K	L	M	N	P
LF-30	182.4	156.4	180.4	150.4	410	295	55	380	30	40	190	162	132	30
LF-40	196.4	166.4	186.4	154.4	500	375	55	470	30	40	250	177	147	30

### Chute Specifications

Unit: mm

Applicable linear feeder	Max. length	Max. width	Max. weight (kg)
LF-30	650	120	3.5
LF-40	750	150	5.5

Note: Chute must straddle drive unit to distribute weight.



### Dimensions 15/30/60/100-liter Hopper

Unit: mm

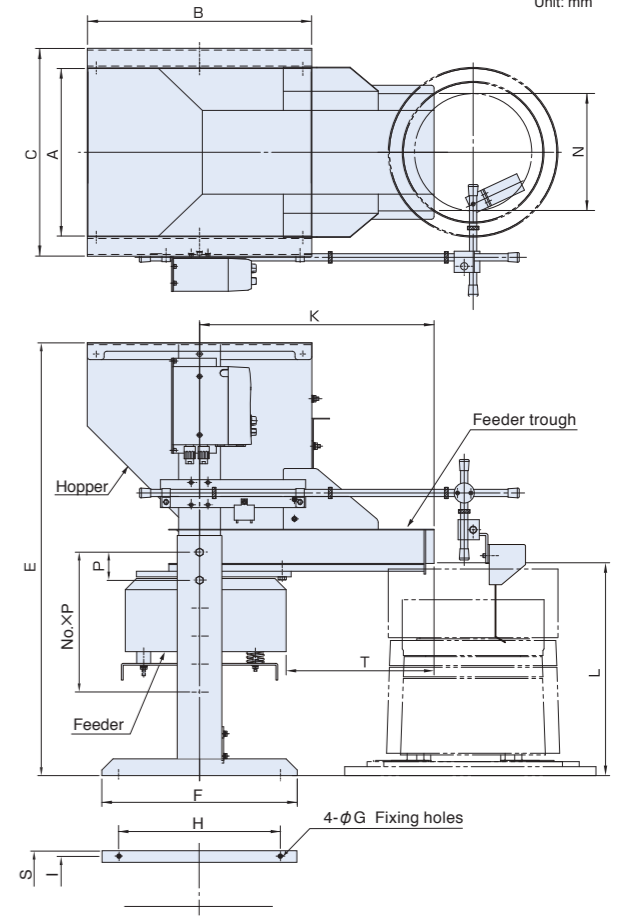

### Features

- By attaching a feeder to a hopper, smooth components feeding is accomplished. Moreover, running noise is extremely low.

### Dimensions Chart, including Feeders

Unit: mm

Hopper capacity (ℓ)	Model	Compatible Parts feeders	Permissible weight of work	A	B	C	E	F	G	H	I	K	L	N	Sliding base No.xP	S	T	Weight (kg)	Electromagnetic feeder	
													Feeder model	Rated current(A)						
15	HPF-15-3815B	EA-25	24	250	350	322	675~875	320	7	270	275	380	381~580	150	5 x 50	310	225	46	CF-2	0.5
		ER-25B																		
		EA-30																		
30	HPF-30-4215B	EA-25	24	300	400	372	775~975	350	7	290	325	420	380~580	150	5 x 50	360	265	50	CF-2	0.5
		ER-25B																		
		EA-30																		
		ER-30B																		
		EA-38																		
60	HPF-60-6030B*	ER-55B	56	450	600	553	865~1215	500	9	400	480	600	430~780	300	8 x 50	536	(358)	140	CF-3	1.0
		ER-65B																		
		ER-55B																		
100	HPF-100-6030B*	ER-55B	56	450	600	553	1015~1365	500	9	400	480	600	430~780	300	8 x 50	536	(358)	147	CF-3	1.0
		ER-65B																		

- Notes
- \*1 Hopper material is stainless steel only.
  - \*2 Vibration frequency: 50~70Hz; rated voltage: 200/220V; compatible controller: C10-1VFEF. (100/110V model is not standard type.)
  - \*3 Paint color: Munsell N7.5
  - \*4 For 15- and 30-liter hoppers, hopper heights becomes 5 levels with 50mm intervals; for 60- and 100-liter hoppers, hopper heights becomes 8 levels with 50mm intervals.
  - \*5 Heavy-duty 60- and 100-liter hoppers (permissible total work weight 112kg) are available as non-standard models.
  - \* Manufactured to order.

### Digital control operated in 'Analog' way

A completely new type of digital controller that can be used with the full line-up of feeders, from high frequency mini parts feeders to small electromagnetic feeders and large size models. With 'analog-style' operation it can be adjusted very swiftly. With an auto-tuning function that eliminates the need for frequency adjustment, and convenient digital settings and display, drive units can be operated to their full potential.



### Dimensions

#### C10-1VF/1VFEF/3VF/3VFEF

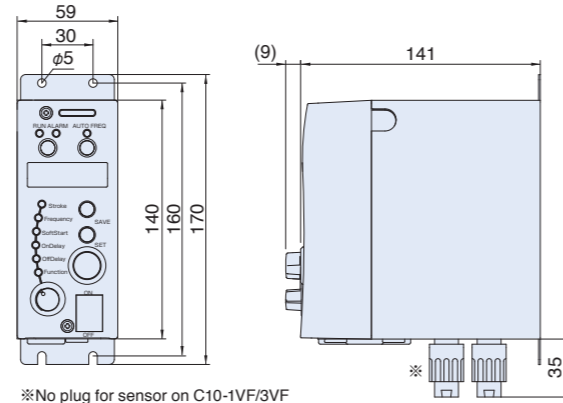

#### C10-5VF/5VFEF

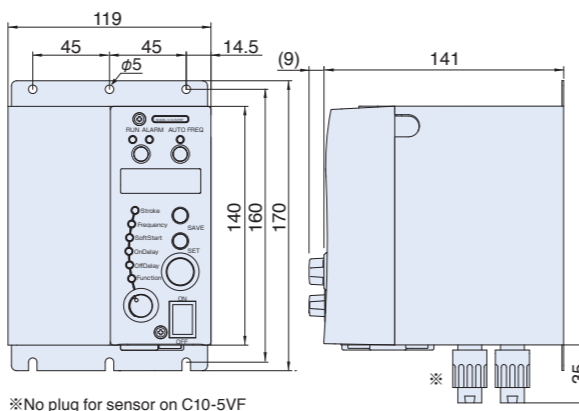

#### C10-TR

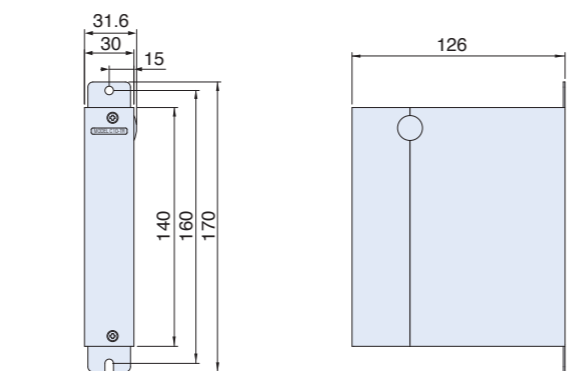

By using a C10-TR power transformer unit with a standard controller, output voltage can be boosted to run an AC 200 V parts feeder from an AC 100 V power source. This is not applicable for C10-5VF(EF).

### Features

- Auto-tuning function eliminates leaf-spring adjustment** (C10-1VFEF, 3VFEF, 5VFEF)  
This digital equipment has a special advanced vibration frequency auto-tuning function. It automatically tracks resonance point changes not only from changes to input volume of workpieces, but also from mechanical changes over time, to deliver optimal vibration at all times. No leaf-spring adjustment or even frequency adjustment is necessary, thereby boosting operation efficiency and saving energy.
- Digital setting and display makes settings easy to manage.**  
Amplitude, drive frequency, output voltage notches are all set and displayed digitally, for easy management.
- Constant amplitude control matched to workpieces or materials** (C10-1VFEF, 3VFEF, 5VFEF)  
Amplitude can be set digitally, and an amplitude sensor allows drive at constant amplitude suited to the workpieces under conveyance.
- Easy-to-use panel design**  
The frequency, voltage, soft start, on delay and off delay settings needed for parts feeder adjustment are located on a control panel. A rotary encoder allows 'analog-style' setting input to be changed to digital values.
- Many external control functions**  
Choice of four speeds can be made by external signal. Two-step control through external regulating resistance. External volume adjustment via a DC4-20mA signal is also possible.
- CE Marking conformed product**  
Required to be installed inside the control box treated with Noise filter and IP4X to make product comply to CE Marking.
- Key lock function**  
To avoid arbitrary setting change by many workers, key lock function is available.
- Capable to switching NPN and PNP**  
No problem with usage in abroad with easy switching.

### C10 Series Parts & Functions

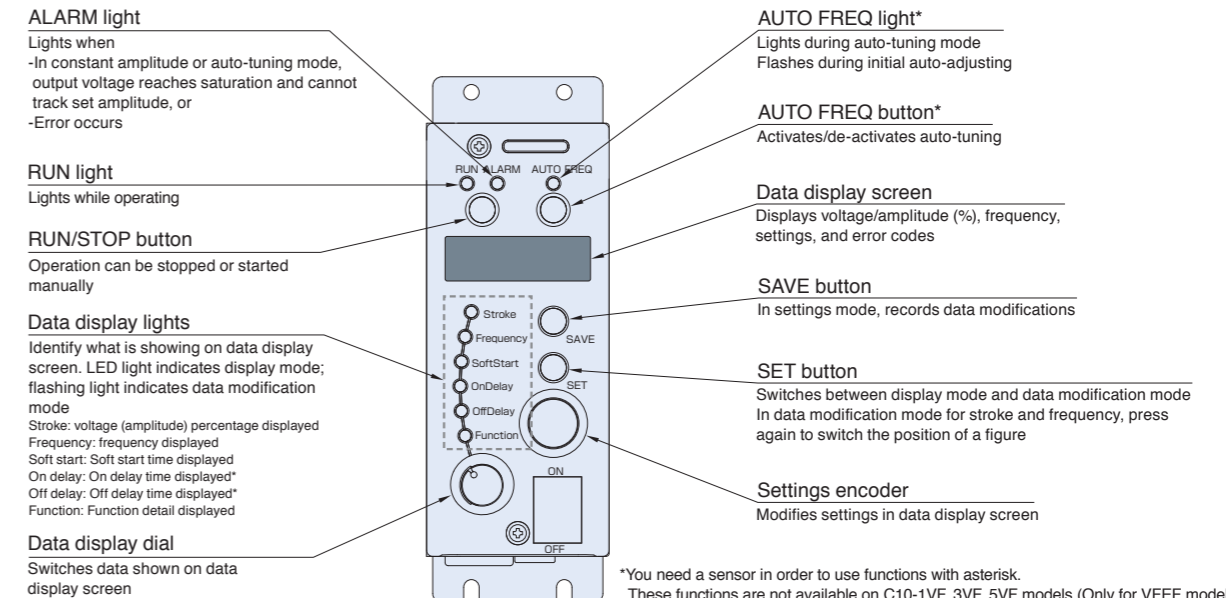

### Specifications

Model	C10-5VF	C10-3VF	C10-1VF	C10-5VFEF	C10-3VFEF	C10-1VFEF	
<b>Input power source</b>	AC100~120V±10%, AC200~230V±10%, 50/60Hz						
<b>Output</b>	<b>Control system</b>	PWM system					
	<b>Voltage</b>	0~190V (for AC 200V input) 0~95V (for AC 100V input) Optional unit C10-TR allows output voltage in 0~190V range (Except C10-5VF(EF)) even with AC100V input					
	<b>Vibration frequency</b>	Half wave: 45~90Hz, Full wave: 90~180Hz Intermediate wave: 65~120Hz, High frequency: 180~360Hz					
	<b>Max. current</b>	5A	3A	1A	5A	3A	1A
<b>Operating modes</b>	<b>Constant voltage mode</b>	Frequency, output voltage set manually					
	<b>Constant amplitude mode</b>	— Constant amplitude control at set frequency					
	<b>Auto-tuning mode</b>	— With frequency auto-tuning, constant amplitude control requires no amplitude setting					
<b>Additional features</b>	<b>Speed selector</b>	Selection of up to 4 amplitude settings by means of external signal					
	<b>Start/stop control</b>	Start/Stop control by external signal Changeable NPN and PNP by switching					
	<b>Output signal</b>	Output signal synchronized to parts feeder operation					
	<b>Soft start</b>	Start-up time 0.2~4.0 secs					
	<b>On/Off delay</b>	—			Delay 0.2~60secs		
	<b>Sensor power source</b>	— For DC 12V, max. 80mA 3P power plug					
<b>Synchronized power output</b>	<b>Function</b>	— Power output synchronized to parts feeder operation (RUN)					
	<b>Control system</b>	— On/Off control					
	<b>Output voltage</b>	— As power source input to controller					
<b>Others</b>	<b>Max. current</b>	— 2A					
	<b>Noise tolerant voltage</b>	Above 1000V					
	<b>Ambient temperature</b>	0~40°C					
	<b>Ambient humidity</b>	10~90% (no condensation)					
	<b>Weight</b>	1.5kg	0.9kg	0.8kg	1.6kg	1.0kg	0.9kg
	<b>Case color</b>	U75-70D (Japan Paint Industry Association)					
<b>Compatible equipment</b>	ER-55B,65B,75B	ER-30B,38B,45B EA-25,30,38,45 LF-30,40	ER-25B EA-15B,20B LFB-350B,450B,600B LFB-300,400,550 LFG-600,750,900 ME-08C,14C HME-08C,14C LFB-02,04 HLFB-02,04C LF-02B,04B MF-04C,15C HSE-14	ER-55B,65B,75B	ER-30B,38B,45B EA-25,30,38,45 LF-30,40	ER-25B EA-15B,20B LFB-350B,450B,600B LFB-300,400,550 LFG-600,750,900 ME-08C,14C HME-08C,14C LFB-02,04 HLFB-02,04C LF-02B,04B MF-04C,15C HSE-14	

Note: Specifications above are applied for later than ver.4.

For source voltage AC200/220V

Single Drive

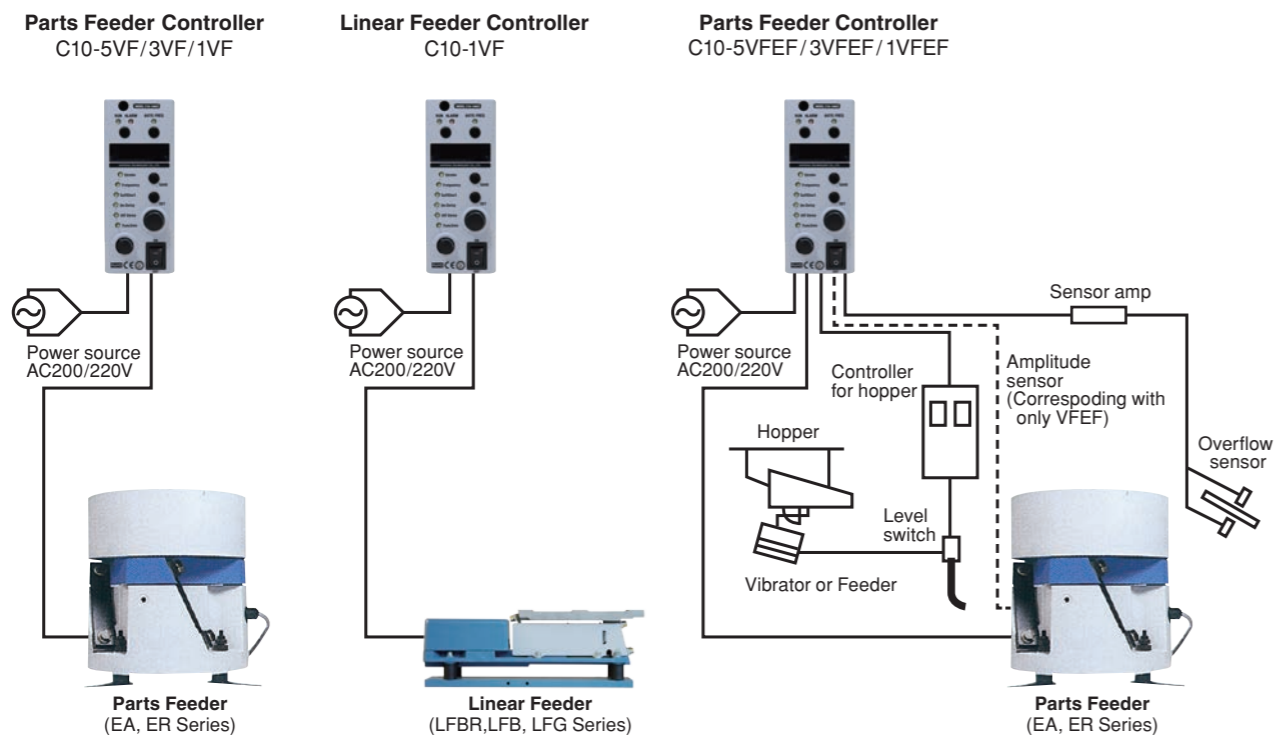

Twin Drive

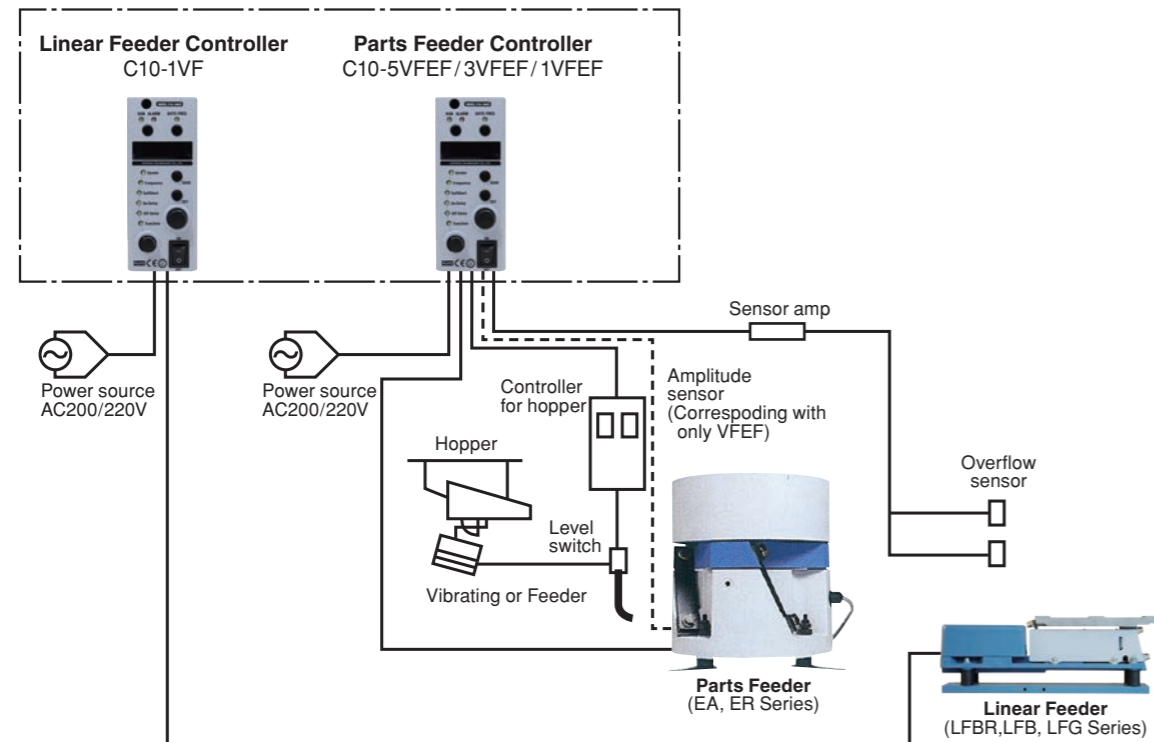

For source voltage AC100/110V

Single Drive

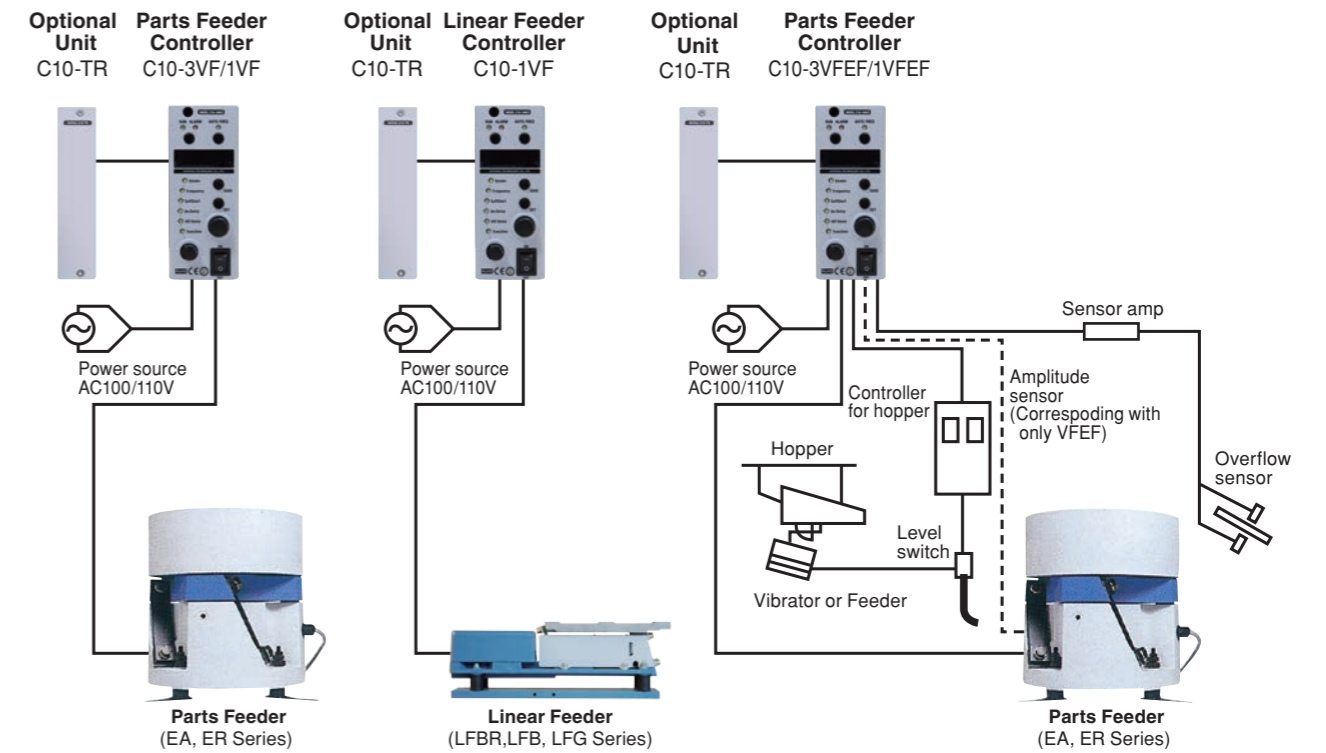

Twin Drive

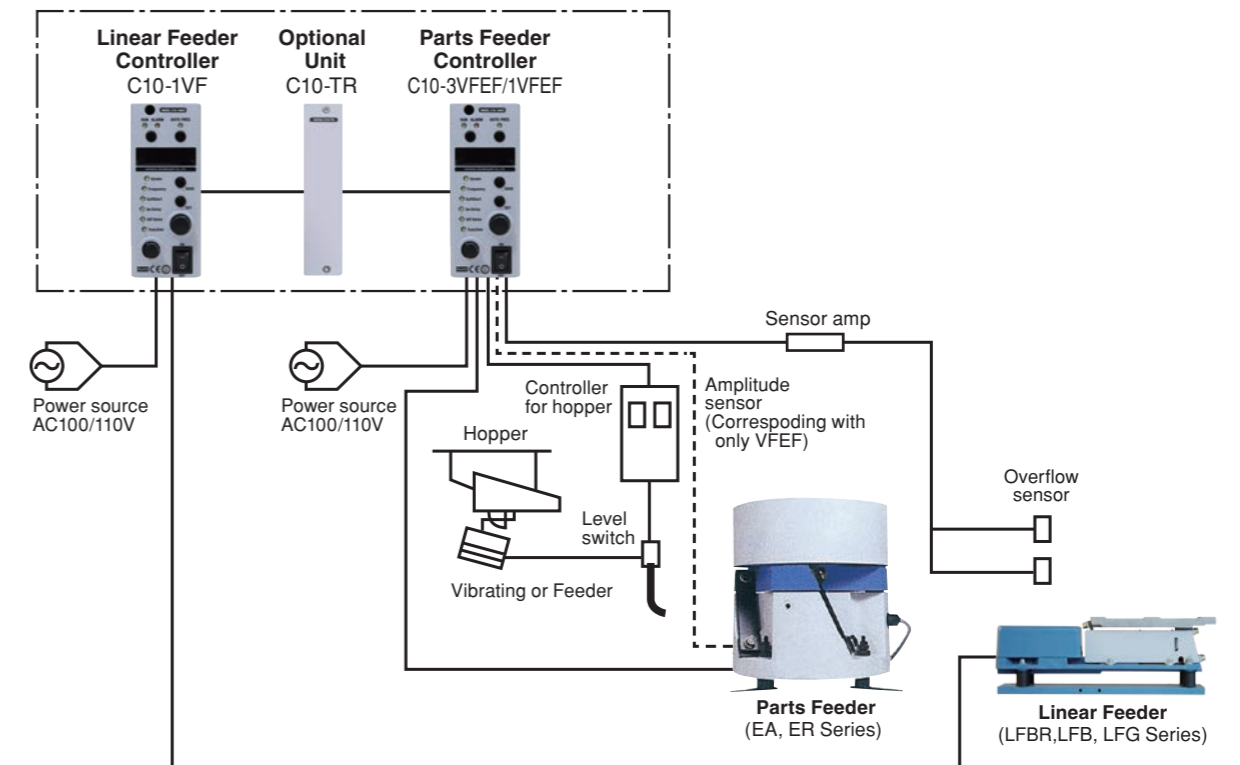

# MINI PARTS FEEDERS

## ME/HME/HSE Series

### High-speed, high-precision handling of micro-sized parts and electronic chips. Compact design and versatility to handle a wide range of small parts.

Designed for the automatic conveyance and stable delivery of delicate components that are easily scratched or damaged, these feeders provide high-speed, high-precision parts handling. With the fine vibration of full wave drive and a soft start function, all types of tiny parts for cameras, watches etc. can be handled. Compact design takes up minimal space.



#### Features

- Smooth, reliable, orderly presentation of tiny, thin parts**  
 High vibration frequency and small amplitude allow for the orderly delivery of micro-sized, thin and complex-shaped parts, which is hard to achieve with conventional feeder vibration characteristics.
- Highly accurate sorting and conveyance**  
 Bouncing of workpieces during conveyance is reduced, and even slight variations in shape and weight distribution of small parts can be detected for accurate sorting.
- No problems at connecting points**  
 With little vibration displacement, there is no damage to workpieces caused by gaps between bowl and chute or chute and non-vibrating parts.
- High vibration frequency gives high speed delivery**  
 High vibration frequency conveys workpieces smoothly, speedily and with no resistance, to supply a stable quantity with little variation, for a significant improvement in efficiency.
- No readjustment of leaf-spring necessary**  
 Once set, leaf-spring requires no further adjustment. With feedback control for amplitude, changes over time in voltage or load do not cause fluctuations in vibration.
- Compact design, with a height adjustment function**  
 Down-sized design for maximum space-saving, with a vibro-isolating base. Bowl height can be adjusted within 3 mm range to simplify positioning.

#### Specifications

Model	Rated Voltage (V)	Rated Current (A)	Vibration frequency (Hz)	Weight (kg)	Loaded weight (kg)	Max. bowl diameter (mm)	Compatible standard controller
ME-08C	100/110	0.30	100~180	2.5	0.6	φ140	C10-1VF C10-1VFEF C9-03VFTC
ME-14C		0.55		7.8	2.0	φ230	
HME-08C		0.15	220~360	2.5	0.6	φ140	
HME-14C		0.30		7.8	2.0	φ230	
HSE-14		0.30		9.3	2.0	φ230	

Note: Loaded weight is permissible weight of bowl and work.

#### Dimensions

Unit: mm

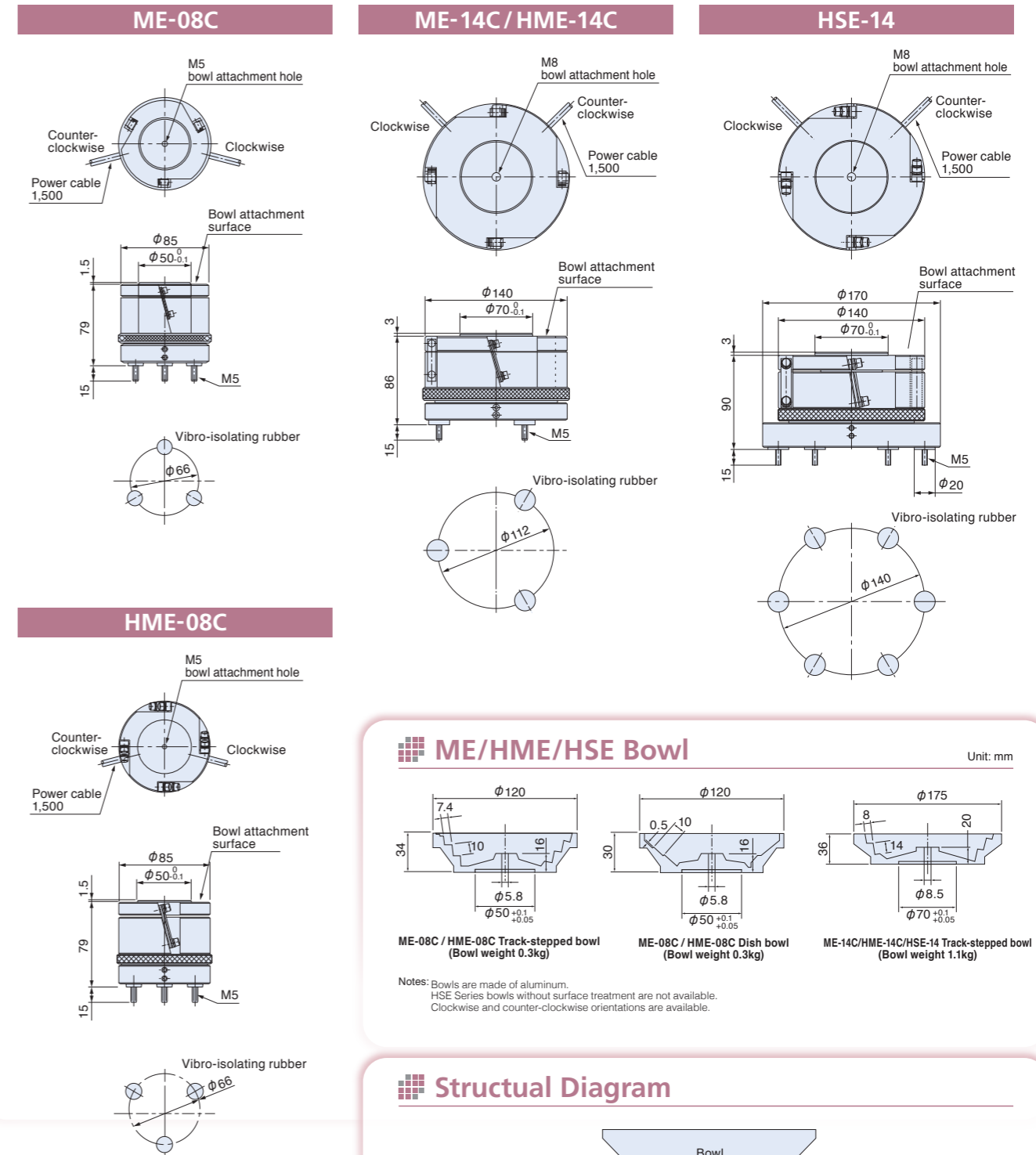

#### ME/HME/HSE Bowl

Unit: mm

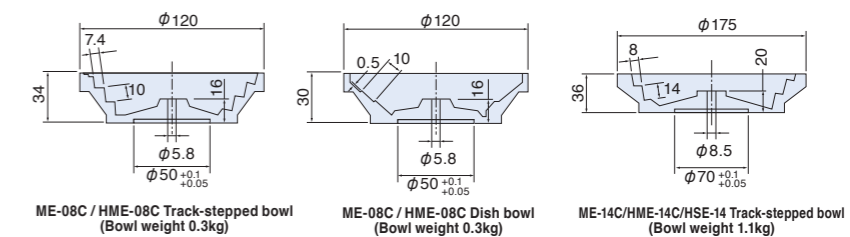

Notes: Bowls are made of aluminum.  
HSE Series bowls without surface treatment are not available.  
Clockwise and counter-clockwise orientations are available.

#### Structural Diagram

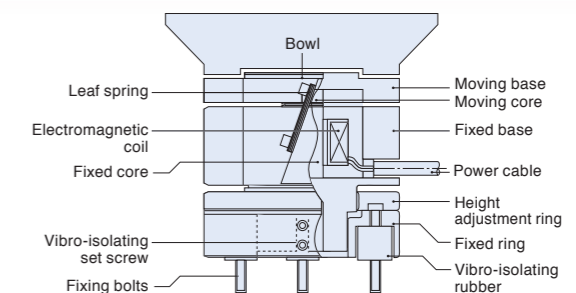



## Ideal vibration characteristics to reduce bouncing

A high-precision electromagnetic drive unit ideal for use with chutes for precision parts, to meet present-day requirements for rapid processing of micro-sized workpieces. Vibro-isolating leaf-springs are installed front and rear to absorb rebound, and vibration characteristics can be adjusted to match the workpiece. Giving uniform vibration the whole length of the trough, this series provides smooth delivery of the most delicate, easily damaged parts with minimal bouncing.

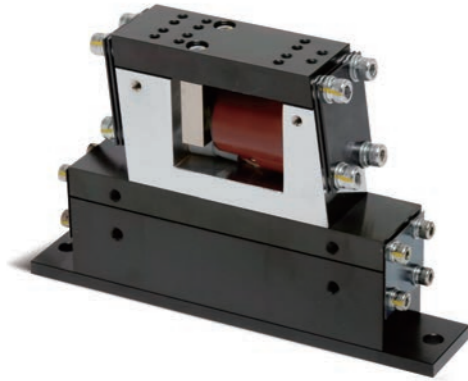

### Features

- **Leaf-spring vibro-isolating type ideal for precision parts**  
This leaf-spring vibro-isolating series is ideal for micro-sized, flat and precision parts.
- **Minimizes bouncing**  
Adjustable vibration characteristics give increased delivery efficiency while minimizing workpiece bouncing.
- **Compact and high precision**  
Compact unit accommodates demands for rapid processing, providing high precision conveyance of micro-sized and precision parts.
- **Reduce Vibration Reaction Force to 1/3 (HLFB-04C)**  
By revising weight balances of movable base and fixed base, it reduced vibration reaction force to 1/3 compared from conventional model.
- **Realized consistent handling speed of works (HLFB-04C)**  
It is able to realize stable supply of work piece with equalize handling speed from chute to outlet by improving degree of leaf springs.
- **14 tapped holes for chute installation (HLFB-04C)**  
By gaining number of tapped hole for chute installation on movable base from 4 to 14, it is suitable for many working conditions.

### Specifications

Model	Rated Voltage (V)	Rated Current (A)	Vibration frequency (Hz)	Weight (kg)	Standard compatible controllers
LFB-02	100/110	0.12	100~180	1.2	C10-1VF C10-1VF EF C9-03VFTC
LFB-04	100/110 200/220	0.16 0.08	100~180	2.7	
HLFB-02	100/110	0.25	220~360	1.2	
HLFB-04C	100/110	0.30	220~360	2.7	

### Dimensions Chart

Unit: mm

Model	A	B	C	E	H	I	J	L	M	N	O	P	R
LFB/HLFB-02	22	130	86	65	15	40	M3	120	φ6	4.5	4.5	5	13
LFB-04	32	170	108	80	20	50	M4	155	φ7	6	49	7.5	15

### Chute Specifications

Unit: mm

Compatible linear feeder	Max.length	Max.width	Max.weight(kg)
LFB/HLFB-02	180	20	0.2
LFB-04	240	30	0.4
HLFB-04C	240	30	0.4

Note: Chute must straddle drive unit to distribute weight.

### Dimensions

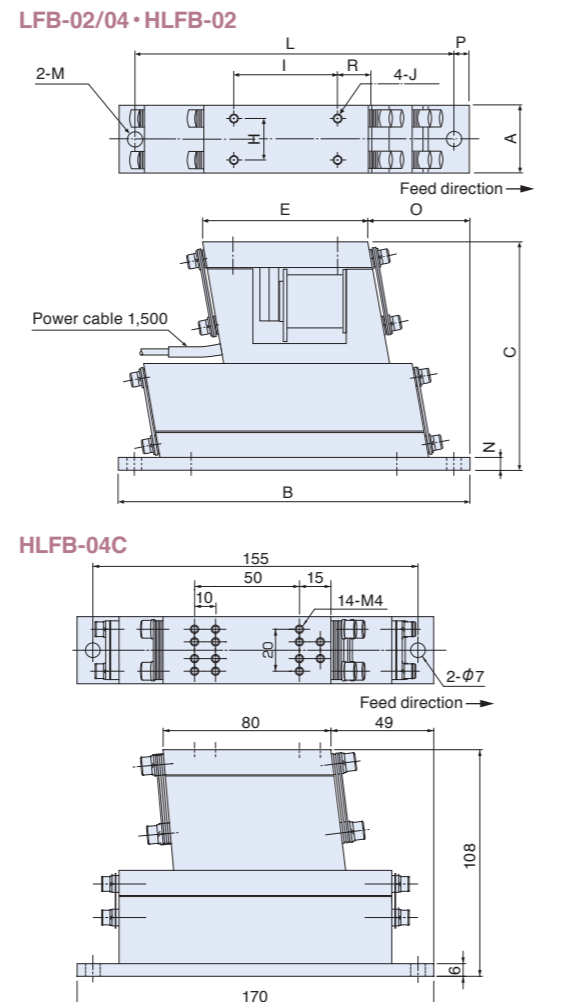

## Digital Control for Revolutionary Delivery of Micro-sized Parts

This new digital controller represents a major advance in the control of high frequency mini parts feeders for delivery of electronic chips and other micro-sized parts. Auto-tuning makes frequency adjustment unnecessary, and with its convenient digital settings and display it enables high frequency mini parts feeders to be operated to their full potential.



### Features

- **Auto-tuning function eliminates frequency adjustments**  
This digital equipment has an advanced vibration frequency auto-tuning function. It automatically tracks resonance point changes not only from variations in workpiece input volume, but also from mechanical changes over time, to deliver optimal vibration at all times. No leaf-spring adjustment or even frequency adjustment is necessary, thereby boosting operating efficiency and saving energy.
- **Digital setting and display makes settings easy to manage**  
Amplitude, drive frequency, output voltage notches are all set and displayed digitally, for easy management.
- **Constant amplitude control matched to workpieces**  
Amplitude can be set digitally, and an amplitude sensor keeps drive at a uniform amplitude suited to the workpieces under conveyance.
- **One controller for all**  
One controller can control both parts feeders or linear feeders.
- **Computerized control delivers optimal drive**

### Dimensions

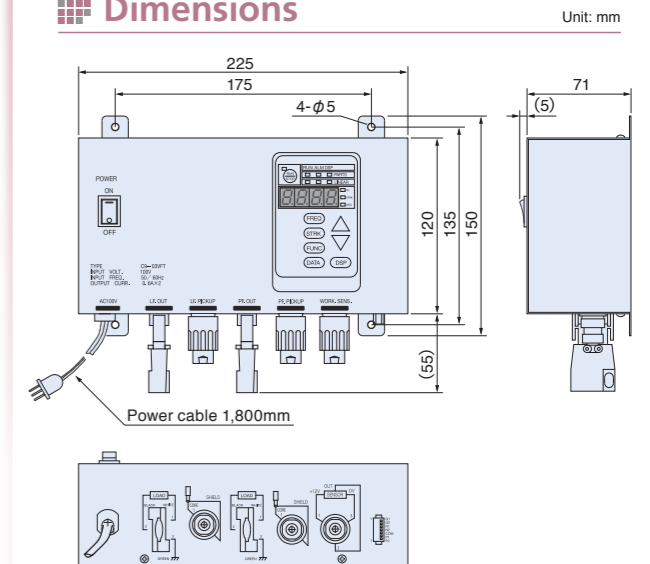

### Specifications

Model	C9-03VFTC	
Input Power source	AC100~230±10%, 50/60Hz	
Control system	PWM system	
Output	Voltage	0~95V
	Vibration frequency	Full wave: 100~180Hz High frequency: 220~360Hz
	Max. current	0.6A
Operating modes	Auto-tuning mode	Automatically senses particular vibration frequencies of parts feeder or linear feeder and controls drive at that frequency
	Constant amplitude mode	Constant frequency control based on frequency setting
Additional features	Speed adjustment	Amplitude adjustable with outer signal (Max. 4 settings)
	Start/Stop control	Start/stop control by external signal
	Overflow control	Sensor allows parts feeder overflow control On/off delay: Variable, 0.2~60 secs
	Sensor power source	DC12V, Max. 80mA for 3 phase socket plug.
	Output signal	Output signal synchronized to operation of parts feeder
	Soft start	Variable, 0.2~0.4 secs
Others	Noise tolerant voltage	Above 1,000V
	Ambient temperature	0~40°C
	Ambient humidity	10~90% (no condensation)
	Case color	Gray(Japan Paint Manufacturer association S-2-1006)
	Weight	1.6kg
Our compatible Parts feeders	ME-08C, ME-14C, HME-08C, HME-14C, HSE14	
Our compatible Linear feeders	LFB-02,04, HLFB-02,04C	